

MULTICALOR 500.1 PRE
MULTICALOR 600.1 PRE



Technical data



Operating instructions



Electric diagrams



Spare parts list



Gas train manual is separate



420011028200

28-02-2019

MULTICALOR 500.1 PRE TC	3145148
MULTICALOR 500.1 PRE TL	3145149
MULTICALOR 600.1 PRE TC	
MULTICALOR 600.1 PRE TL	3145151

INDEX

MULTICALOR 500.1

MULTICALOR 600.1

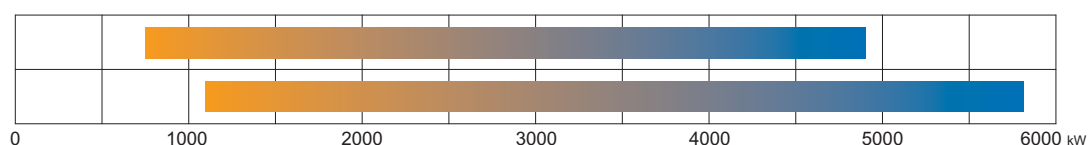

General warnings - Conformity declaration	3
Burner designation - Modular delivery system	4
Burner description	5
Electrical control panel	5
Gas train - Kit - Accessories: assembly to the burner	6
Technical data	7
Gas category by country	7
Working diagrams	8
Test boiler - Flame dimension	8
Overall dimensions	9
Oil operating mode - General safety functions	10
Gas operating mode - General safety functions	11
Installation	12
Fitting the burner to the boiler	12
Oil connection	13
Feeding and suction line for light oil	14
Gas line	15
Pilot gas train, kit and accessories connection - Head loss diagram	16
Gas pressure loss diagrams	17
Electrical connections	19
Start-up: Checking procedure, Recording commissioning data	20
Exhaust gas test	21
Start-up oil side	22
Fuel selection - Start-up	22
Adjusting the max air flow rate	22
Firing head setting	22
Adjusting the max oil flow rate	23
Servomotor Lamtec - Air damper motor pre-setting	23
Adjusting the pump pressure	23
Adjusting the intermediate burner capacity	24
Start-up gas side	25
Fuel selection - Start-up	25
Adjusting the max air flow rate	25
Firing head setting	25
Servomotor Lamtec - Air damper motor pre-setting	25
Adjusting the intermediate burner capacity	26
Pressure switch adjustment	26
Maintenance program	27
Troubleshooting instructions	29
Operating troubles	29
Appendix	29
Control box - Damper actuators	29
Fluidics nozzle chart	30
Bergonzo nozzle tables	33
Pump and pressure regulators	36
Electrical diagrams	37
Spare parts list	44

GENERAL WARNINGS - CONFORMITY DECLARATION

Important notes

Ecoflam burners have been designed and built in compliance with all current regulations and directives.



All burners comply to the safety and energy saving operation regulations within the standard of their respective performance range.



The burner must not operate outside the working range.

The quality is guaranteed by a quality and management system certified in accordance with ISO 9001:2008.

MULTICALOR burners are designed for the low-pollutant combustion of natural gas or LPG with kit and light oil.



The burners comply with standard EN676. Assembly and commissioning must be carried out only by authorised specialists and all applicable guidelines and directives must be observed.

Burner description

MULTICALOR PRE burners are progressive electronic fully automatic monoblock devices. Burner head is designed to get the lowest emissions in terms of NOx and unburnt particles in order to maximize the heat generator efficiency. Emissions can be different respect to the ones recorded in the lab because they depends a lot on the generator on which the burner is fit.

The installer must comply with compulsory rules. Avoid for instance dangerous atmosphere or not ventilated rooms.

Packaging and handling

Move the burner still in its packaging using a trolley or forklift, taking care not to drop it and elevating it no more than 20cm from ground level. After having removed the packaging, check that the contents are in good condition and correspond with what was ordered. If in doubt, contact the manufacturer.



The burner must be installed by a qualified individual.

If the weight and dimensions do not allow for manual lifting, ask another operator for

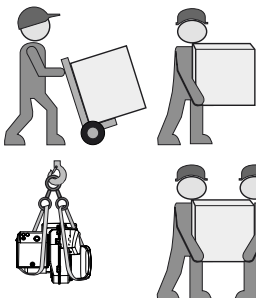

help or use a forklift, harness the burner using belts if no eyebolts are available.



Use the accessories provided (flange, gasket, pins and nuts) to install the burner onto the boiler, taking care not to damage the isolating gasket.

We can accept no warranty liability whatsoever for loss, damage or injury caused by any of the following:

- Inappropriate use.
- Incorrect assembly or repair by the customer or any third party, including the fitting of non-original parts.
- non authorised modifications made on the burner.

Provision of the system and the operating instructions

The firing system manufacturer must supply the operator of the system with operating and maintenance instructions on or before final delivery. These instructions should be displayed in a prominent location at the point of installation of the heat generator, and should include the address and telephone number of the nearest customer service centre.

Notes for the operator

The system should be inspected by a specialist at least once a year. It is advisable to take out a maintenance contract to guarantee regular servicing.

Gas lines

When installing the gas lines and gas train, the general EN676 directives and guidelines must be observed. Additional accessories and kits shall be installed by the installer in accordance to the local safety regulations and codes of practise.

Installation location

The burner must not be operated in rooms containing aggressive vapours (e.g. spray, perchloroethylene, hydrocarbon tetrachloride, solvent, etc.) or tending to heavy dust formation or high air humidity. Adequate ventilation must be provided at the place of installation of the furnace system to ensure a reliable supply with combustion air.

Installing the gas train



The gas train is supplied separately, for fitting refer to the instructions in the gas train manual.

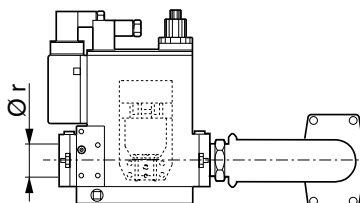

Declaration of conformity for dual fuel burners

We,
Ecoflam Bruciatori S.p.A.

declare under our sole responsibility that the dual fuel burners named

MULTICALOR

conform to the following standards:

EN 267	EN 50156-1
EN 676	EN 55014-2
EN 55014-1	EN 60335-2-102
EN 60335-1	EN 61000-6-3
EN 61000-6-2	

These products bear the CE mark in accordance with the stipulations of the following directives:

2014/35/UE Low Voltage Directive
2014/30/UE EMC Directive
2006/42/EC Machine directive
2011/65/EU RoHS2 directive
(EU) 2016/426 Gas Appliance Regulation.

April, 2018 / Mr. Filippo Maltempo

R&D Director

General regulations applying to the gas connection

- The gas train must only be connected to the gas mains by a recognised specialist.
- The cross-section of the gas line should be of a size designed to guarantee that the gas flow pressure does not drop below the specified level.
- A manual shut-off valve (not supplied) must be fitted upstream of the gas train.



BURNER SELECTION: Type of operation and configuration must be done by professional personnel in order to grant correct working of the burner. Installation, start-up and maintenance must be carried out by authorised specialists and all applicable guidelines and regulations (including local safety regulations and codes of practise) must be observed.

BURNER DESIGNATION

MULTICALOR 500.1 PRE TC

RANGE NAME BY FUEL TYPE

MULTICALOR Dual fuel (Gas / Light oil)

MODEL SIZE (Gas: kW; Oil: kg/h)

MULTICALOR 500.1 423 kg/h - 5000 kW

EMISSIONS

- Standard Class 2 - GAS EN676 (<120 mg/kWh)
- Стандартная, класс 1 - Дизтопливо EN267 (<250 мг/кВтч)

OPERATION TYPE

PR 2 stages progressive mechanical gas / oil
PRE 2 stages progressive electronic with PID

HEAD TYPE

TC Short head
TL Long head

FUEL

Natural gas
LPG Liquid gas
BIOGAS Biogas

MODULAR DELIVERY SYSTEM

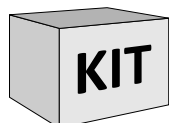
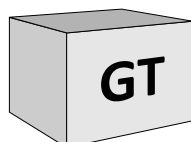
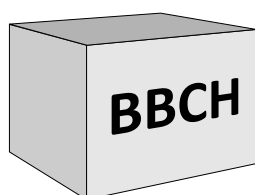

Dual fuel burners

All dual fuel burners are delivered in separate set/box, i.e. burner body including combustion head and separate gas train with separate additional kit and accessories that shall complete the gas train or the burner according to the applicable standard. Kit and accessories are delivered separately.

Gas train - GTCP - KITS - Accessories

All gas and dual fuel burners gas trains are delivered separately in different models and configuration.

Export configuration gas train completion are available but it is mandatory for the local installer in this case to comply to the local safety regulations.

For burners over 1700 kW gas train connection pipe must be ordered.

Kits and accessories are managed and delivered separately.

Component type

BBCH	Burner Body with Combustion Head (without gas train)
GTCP	Gas Train Connection pipe
GT	Gas Train (delivered separately)

BURNER DESCRIPTION

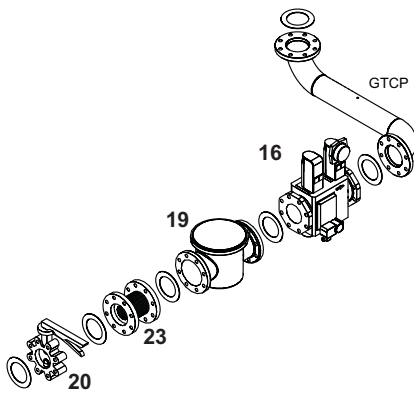
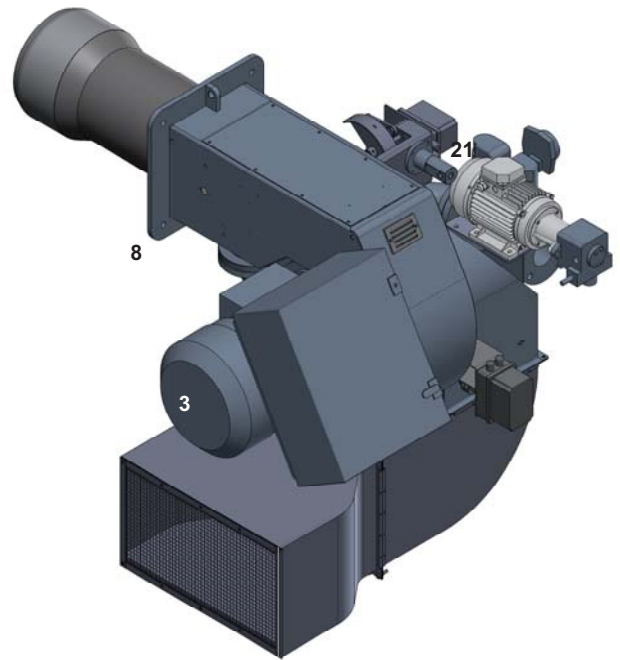
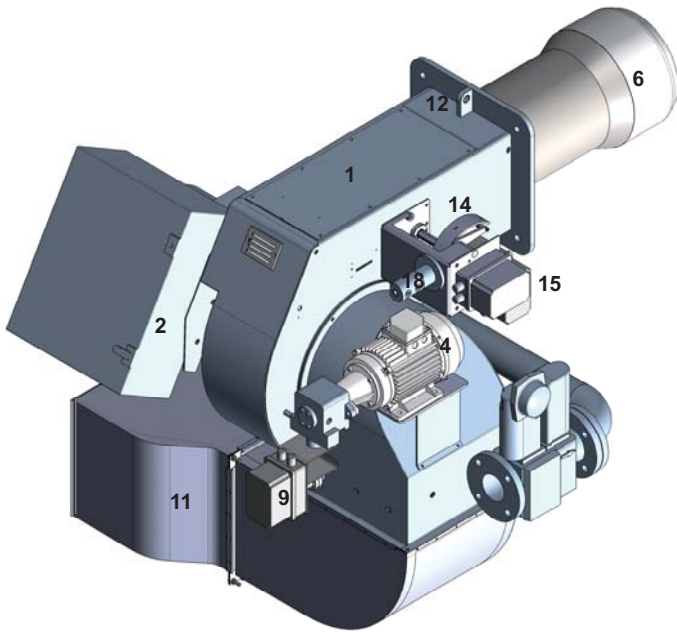

LEGENDA

- 1. Housing
 - 2. Electrical control panel
 - 3. Blower motor
 - 4. Pump and pump motor
 - 6. Blast tube
 - 8. Burner fixing flange
 - 9. Air flap regulation
 - 11. Silencer
 - 12. Lifting eyebolts
 - 14. Mechanical cam oil
 - 15. Servomotor for gas and air
 - 16. Gas train
 - 17. Pilot gas train
 - 18. Oil pressure regulator
 - 19. Gas filter
 - 20. Ball valve
 - 21. Oil coil
 - 23. Antivibration coupling
- GTCP. Gas train connection pipe

Control panel

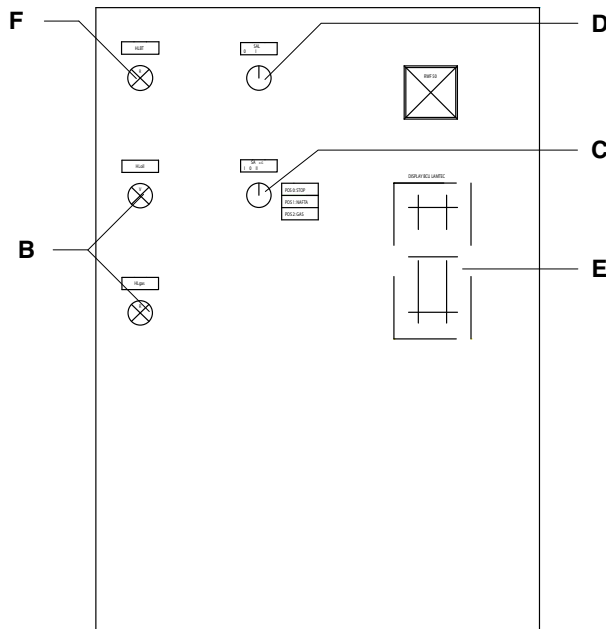

- F - thermal lock-out lamp
- B - operating lamps (orange=light-oil; green= gas)
- C - selector:
 - 0 = STOP
 - 1 = light-oil operation
 - 2 = gas operation
- D - ON/OFF switch
- E - display

BURNER DESCRIPTION

Gas train - Kit - Accessories: assembly to the burner

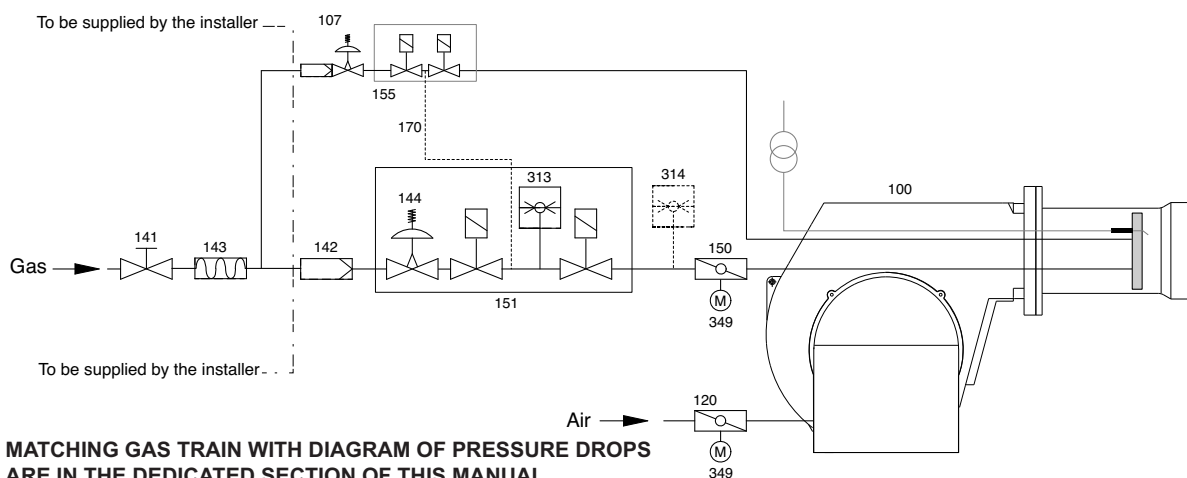

MATCHING GAS TRAIN WITH DIAGRAM OF PRESSURE DROPS ARE IN THE DEDICATED SECTION OF THIS MANUAL

Ecoflam gas trains are delivered separately for all gas and dual fuel burners and are available in different configurations:
Double gas valves with actuators and regulator VGD Siemens and min pressure switch + ACS gas filter

VGD 20.503 Rp 2" / VGD 40.065 - 40.080 - 40.100 - 40.125				
	1. Main gas pipe			
	2. Ball valve		ACS	
	3. Antivibration coupling		ACS	
	5. Min gas pressure switch	EXPORT	GAS TRAIN	EN676
	6. Safety gas valve + 10. Actuator			
	7. Working gas valve + 11. Actuator			
	8. Gas leakage control		KITTC *	
	9. Gas filter		ACS	
	KIT - MAX Gas pressure switch		KITPRES	
ACS - Gas train connection pipe		GTCP **		

! **GTCP-...* WARNING:** in order to fit the gas train, the corresponding connection pipe must be ordered (GTCP size and fitting depend on the burner and the gas train selected). Upon the installer responsibility it is mandatory to install additional support(s) in order to not overload the burner body with the dead load of full gas train, accessories, piping and so on.
 The burner body can stand just the gas valve and the piping between the gas valve and the body.

HOW TO INSTALL THE GAS TRAIN INTO THE BURNER AND CALCULATE THE OVERALL DIMENSIONS:

refer to the dimension page and the gas train manual for all detailed information

! **WARNING:** EN676 compulsory kit and accessories in order to comply to the safety regulations. Additional accessories and kits shall be installed by the installer in accordance to the local safety regulations and codes of practise.

Gas governor / Filter	Modulation Kit	Max Pressure switch	Other accessories
FGDR - FILTER	KITMD-RWF50	KITPRES50	
Compulsory EN676	Probe-...	KITPRES150	

TECHNICAL DATA

MODEL		MULTICALOR 500.1 PRE	MULTICALOR 600.1 PRE
Thermal power max.	kW	5.000	5.800
	kcal/h	4.300.000	4.988.000
	kg/h	423	490
Thermal power min.	kW	1.200	1.500
	kcal/h	1.032.000	1.290.000
	kg/h	101	126
Operation mode	Type	Progressive electronic oil / gas - Modulating with PID	
Regulation ratio nominal	Type	1÷4 GAS - 1÷3 OIL	
Fuel	Type	G20 (L.C.V. 8.570 kcal/Nm ³), G25 (L.C.V. 7.370 kcal/Nm ³) G31 (L.C.V. 22.260 kcal/Nm ³), G30 (L.C.V. 29.320 kcal/Nm ³) Light oil (L.C.V. 10.200 kcal/kg max visc. 1,5°E at 20°C)	
Emission class	std	Standard Class 2 GAS EN676 (<120 mg/kWh) - Standard Class 1 OIL EN267 (<250 mg/kWh)	
Control unit	Type	LAMTEC BT3xx	
Gas train	GT	VGD separate gas train + Filter + Other KIT/ACS	
Gas connection	GTCP	Gas connection range RP 50 to DN 125 depending on the gas train selected	
NATURAL GAS pressure	mbar	35÷500	50÷500
LPG pressure	mbar	65÷500	90÷500
Air regulation	Type	Air flap	Air flap
Air flap control with servomotor	Model	STE....	
Air pressure switch	mbar	1...10 mbar	
Flame monitoring	Type	UV cell QRA	
Ignitier	Model	BRAHMA	
Motor	kW	11	18
Rpm	N°	2.800	2.800
Voltage	V/Hz	230/400 V - 50 Hz	
Total power consumption operation	kW	13,5	17,5
Weight body BBCH	Kg		
Electrical panel protection level	IP	IP55	IP55
Sound pressure level without silencer	dB(A) Lab tests	91,4	92,8
Sound pressure level with silencer		85,7	86,7
Ambient temperature storage	Min/Max	-20°...+70° C	
Ambient temperature use		-10°...+60° C	
Oil pump	Model	TA4	TA4
Oil pump motor	kW	1,1	1,1
Nozzles	Type	according to the output requested	

GAS CATEGORY BY COUNTRY

Gas category	Country																									
	BE	CH	CZ	DE	DK	ES	FI	FR	GB	GR	HU	IE	IT	LU	NL	PT	SE	EE	LT	LV	NO	PL	SK	SI	-	
II _{2R3R}																										
II _{2H3B/P}	AT	-	-	-	-	-	-	-	-	-	-	-	-	-	-	-	-	-	-	-	-	-	-	-	-	-
I _{3R}	CY	MT	-	-	-	-	-	-	-	-	-	-	-	-	-	-	-	-	-	-	-	-	-	-	-	-

WORKING DIAGRAMS

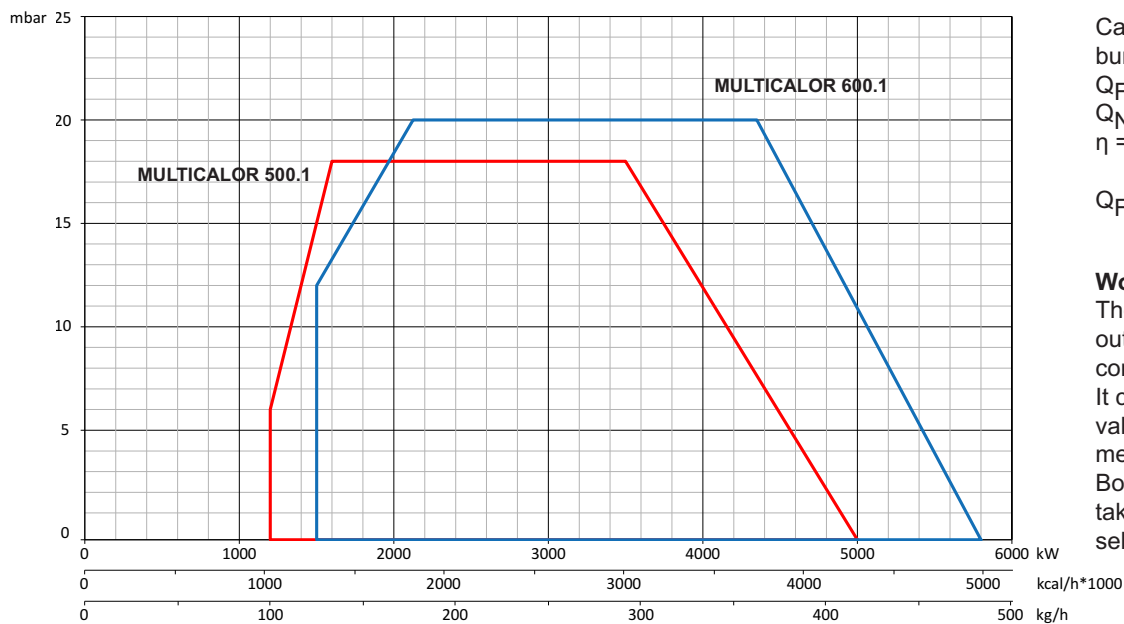

Calculation of burner output
 Q_F = Burner output (kW)
 Q_N = Rated boiler output (kW)
 η = Boiler efficiency (%)

$$Q_F = \frac{Q_N}{\eta} \times 100$$

Working fields

The working field shows burner output as a function of combustion chamber pressure. It corresponds to the maximum values specified by EN 676 measured at the test fire tube. Boiler efficiency should be taken into consideration when selecting the burner.

TEST BOILER - FLAME DIMENSIONS

FLAME LENGTH GAS BURNERS

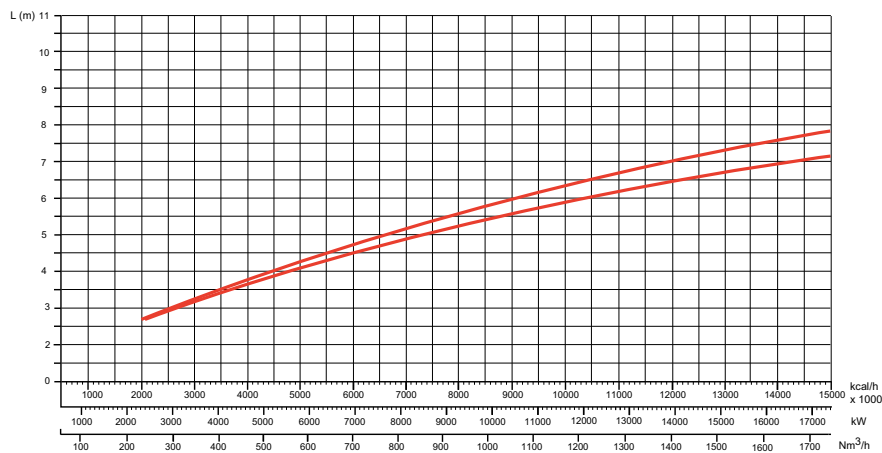

FLAME DIAMETER GAS BURNERS

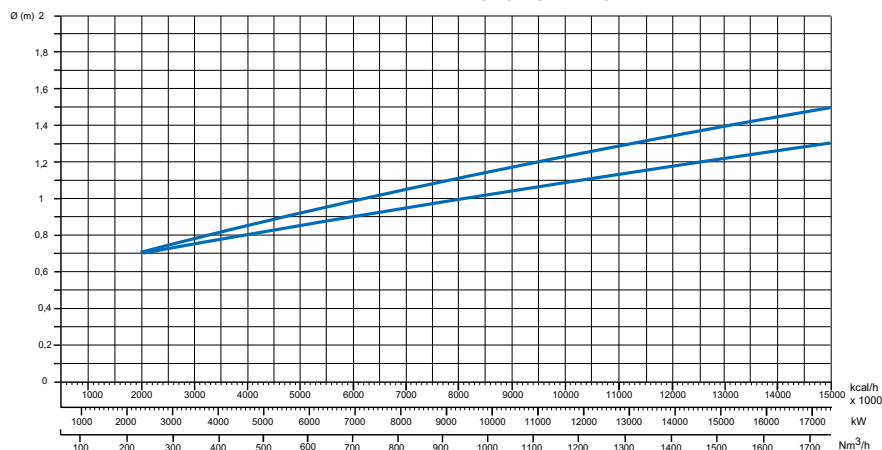

The burner/boiler matching does not pose any problems if the boiler is CE type-approved.

If the burner must be combined with a boiler that has not been CE type-approved and/or its combustion chamber dimensions are clearly smaller than those indicated in diagram, consult the manufacturer.

The firing rates were set in relation to special test boilers, according to EN676 - EN267 regulations.

The sizes are indicative and depend on the configuration, to the combustion chamber pressure and to the draught. The values have been taken out from tests executed with flame tubes.

The dimensions of the flame are made in test boiler in laboratory without resistance therefore exists max and min length that take into account the difference in length that comes from the boiler backpressure.

Example:

Burner thermal output = 8000 kW;

L flame (m) = 5 m (medium value)

D flame (m) = 1 m (medium value)

WARNING: Some flame modifications can be done in our FLEXSHOP in the factory in order to shape the flame and adapt it to some special boiler or application.

OVERALL DIMENSIONS

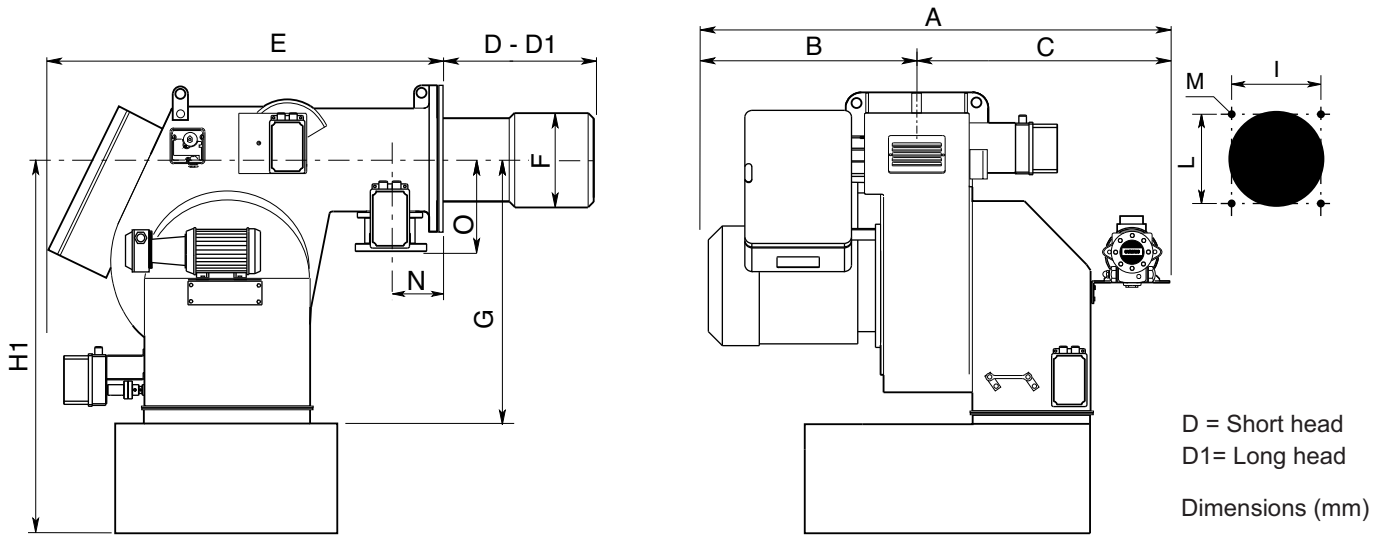

D = Short head
D1= Long head
Dimensions (mm)

Model	A	B	C	D	D1	E	F	G	H1	I	L	M	N	O
MULTICALOR 500.1	1200	580	610	355	555	1000	320	570	965	330	330	M16	195	250
MULTICALOR 600.1	1200	580	620	355	555	1095	320	570	975	330	330	M16	195	250

HOW TO INSTALL THE GAS TRAIN INTO THE BURNER AND CALCULATE THE OVERALL DIMENSIONS:

refer to the dimension page and the gas train manual for all detailed information.

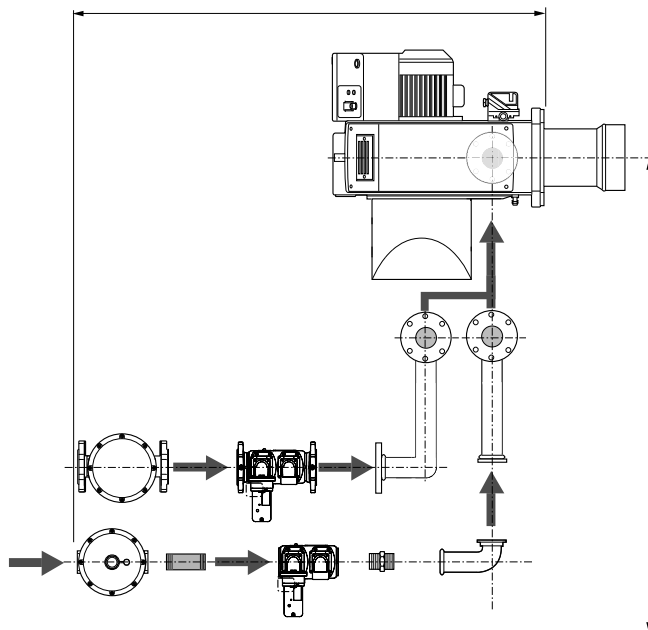

Burner-boiler mounting flange

Fixing hole dimensions are "I" and "L" as per dimension table. Boiler hole shall be done according to the blast tube dimension "F" plus 15-25 mm in order to be able to extract it during maintenance.

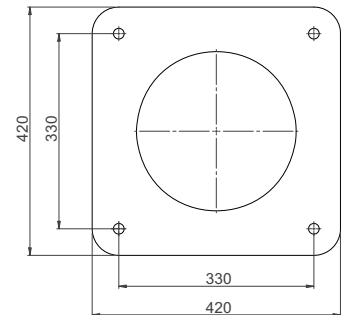

WARNING: Please follow the suggested dimension for the hole on the boiler flange in order to fit the burner. Make sure that between the boiler and the blast tube proper insulation is fitted.

Burner gas flange

Model	Ø A1	B1
MULTICALOR 500.1	145	4 x M16
MULTICALOR 600.1	145	4 x M16

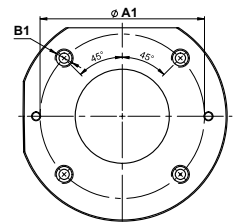

Packaging (only burner)

Model	X	Y	Z	kg
MULTICALOR 500.1	1580	1630	1090	
MULTICALOR 600.1	1580	1630	1090	

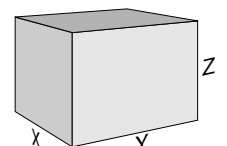

OIL OPERATING MODE - GENERAL SAFETY FUNCTIONS

START-UP MODE

As soon as the furnace system is required to supply heat, the burner control circuit will close and the program flow started. When the program has come to its end, the burner will be turned on.

An automatic test is made for the tightness of the gas valves prior to each burner start. The air damper is in its closed position when the burner is out of operation.

The electric actuator will open the closed air damper to its full-load position so that the burner will ventilate the furnace and the exhaust hoods with the specified air rate.

Shortly after the prevention process has been started the lack-of-air cut-out must change over to operating position within a certain time, i.e. the minimum air pressure setting must be reached and maintained until the burner is turned off. At the end of the specified pre-ventilation time the air damper will be moved into its partial-load position in a linked control concept with the gas damper. This operation will be followed by the pre-ignition procedure and the oil feed start.

The solenoid valves will open and thus allow the pressurized oil to flow to the nozzle and to the return line.

The oil will be atomized, mixed with the

combustion air and ignited.

A safety period is provided to allow the flame to develop a proper and steady pattern.

On the termination of the safety period, a flame signal must have been received by the control box via the flame monitor and remain on until the regular shut-off.

The startup program of the burner has now been completed.

OIL OPERATING MODE

After the flame has developed the load regulator will be enabled which brings the burner into its operating position.

The load regulator will now control the burner automatically between its partial-load and full-load stages.

Depending on the heat demand, the electric actuator of the mechanical compound control system will be fed with the OPEN or CLOSE signal via the regulator and thus increase or decrease the oil and air flow rates.

This compound control system will vary the positions of the oil control valve and air damper and thus regulate the oil flow rate in conjunction with the air flow rate. The

burner can either be controlled in two-stage sliding mode or, if a respective controller is provided, in stepless control mode.

The stepless control will allow the burner to be operated at any desired stage between its partial-load and full-load positions. The burner will be turned off from its partial-load position. The air damper will be closed when the burner is out of operation and will thus prevent cold air flowing through the burner chamber, heat exchanger and chimney.

The interior cooling losses will be greatly minimized.

GENERAL SAFETY FUNCTIONS

In case a flame does not develop when starting the burner (fuel release) the burner will shut off at the end of the safety period (safety lock-out).

A safety lock-out will also occur in the case of flame failure during operation, air flow failure during the pre-ventilation phase and pressure failure during the whole period of burner operation.

Any failure of the flame signal at the end of the safety period and a flame signal during

the pre-ventilation phase (external light control) will result in a safety lock-out with the control box being locked.

The trouble is indicated by the trouble signal lamp lighting up.

The control box can be unlocked immediately after a safety lock-out by pressing the unlocking key. The program unit will return to its starting position and proceed with the restart of the burner. A voltage failure will result in a regular shut-off of the burner. Upon voltage

recovery there may be an automatic restart unless another interlock is provided, e.g. by the safety system. In any case of trouble the fuel oil supply will be shut off right away. The program unit will stop at the same time causing also the trouble location indicator to stop. The symbols will indicate the kind of trouble.

GAS OPERATING MODE - GENERAL SAFETY FUNCTIONS

START-UP MODE

As soon as the furnace system is required to supply heat, the burner control circuit will close and the program flow started. When the program has come to its end, the burner will be turned on.

An automatic test is made for the tightness of the gas valves prior to each burner start. The air damper is in its closed position when the burner is out of operation.

The electric actuator will open the closed air damper to its full-load position so that the burner will ventilate the furnace and the exhaust hoods with the specified air rate.

Shortly after the prevention process has been started the lack-of-air cut-out must change over to operating position within a certain time, i.e. the minimum air pressure setting must be reached and maintained until the burner is turned off. At the end of the specified pre-ventilation time the air damper will be moved into its partial-load position in a linked control concept with the gas damper.

The ignition transformer will be started.

At the end of the pre-ignition time the ignition gas solenoid valves will be opened to allow gas to flow into the pilot burner.

The ignition electrodes incorporated in the pilot burner will ignite the ignition gas.

The ionization probe gives flame signal to

control box so that the safety shut-off valves will be opened.

The gas will be fed to the gas nozzles via the gas damper while combustion air is supplied by the fan.

Gas and air will be intensively mixed in the mixing unit and ignited by the pilot flame with a specified safety period (minimum furnace heat generating rate).

After the safety period has run down the pilot burner will be turned off.

Attention:

If there are shut-off dampers in the flue gas tract they must be completely open. Otherwise there will be a high danger of low-speed detonation or explosion!

GAS OPERATING MODE

After the flame has developed the load regulator will be enabled which brings the burner into its operating position.

The load regulator will now control the burner automatically between its partial-load and full-load stages. Depending on the heat demand, the electric actuator of the compound control system will be fed with the OPEN or CLOSE command via the regulator and thus increase or

decrease the gas and air flow rates.

This compound control system will vary the positions of the gas control valve and air damper and thus regulate the gas flow rate in a linked concept with the air flow rate. The burner can either be controlled by a 2-stage sliding or, if a respective controller is provided, a stepless control concept.

The stepless control will allow the burner to be operated at any desired stage between its partial-load and full-load positions.

The burner will always be turned off out of its partial-load position.

The air damper will be closed when the burner is out of operation and will thus prevent cold air flowing through the burner chamber, heat exchanger and chimney.

The interior cooling losses will thus be greatly minimized.

Scheme of functioning

LEGENDA

- 107: pilot gas filter/governor
- 141: ball valve
- 142: filter
- 143: antivibration coupling
- 150: butterfly valve
- 151: gas train Siemens VGD
- 155: pilot gas train
- 176: oil pump
- 178: solenoid valve
- 184: output control valve
- 311: return oil pressure switch
- 313: min gas pressure switch
- CV: check valve
- RL: return line
- VL: suction line
- VLO: working oil valve

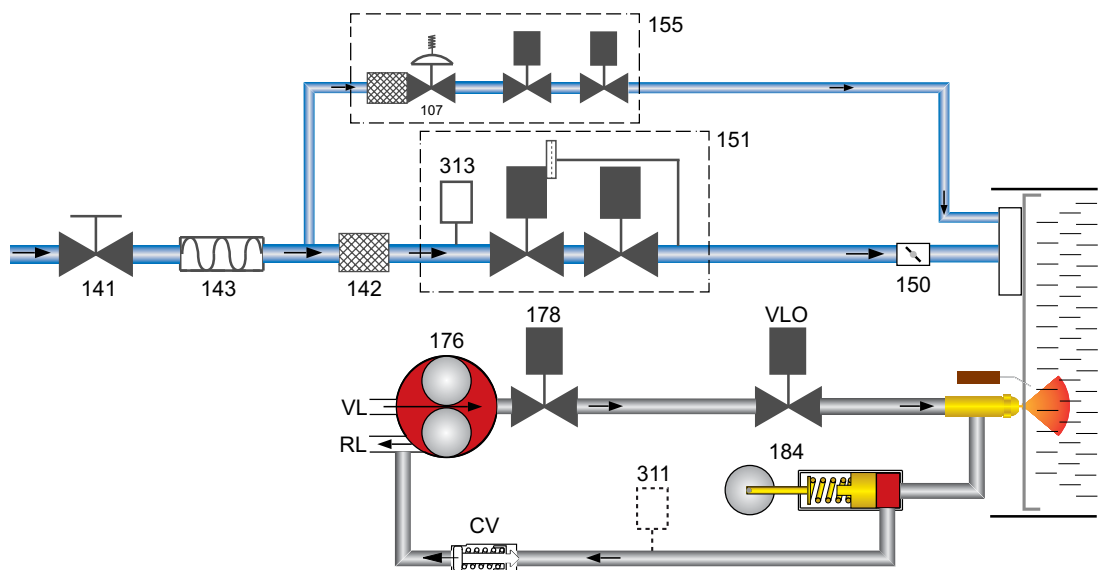

INSTALLATION

Fitting the burner to the boiler



WARNING: handling and moving operations must be carried out by specialised personnel. Use the eyebolts to lift the burner in order that it will not overturn and fall down.

To perform the installation of the burner into the boiler drill the boiler plate according to the dimension given on this manual and place the burner towards it by lifting and moving the burner by means of eyebolts.

Place the gasket on the burner flange and install the burner into the boiler by fixing nuts into the bolts.

The space between the blast tube and the boiler lining must be sealed with appropriate insulating material.

Burner blast tube insertion depth and brickwork

Unless otherwise specified by the boiler manufacturer, heat generators without a cooled front wall require brickwork or insulation 5 as shown in the illustration. The brickwork must not protrude beyond the leading edge of the blast tube, and should have a minimum conical angle of 60°. Gap 6 must be filled with an elastic, non-combustible insulation material. For boilers with reverse firing, the minimum burner tube insertion depth A as specified in the boiler manufacturer's instructions must be observed.

On boilers the blast tube insertion depth should be observed as per the boiler manufacturer's instructions.

Reverse flame boiler :

A = 50-100 mm.

Three pass boilers :

A1 = 50-100 mm.

Exhaust system

To avoid unfavourable noise emissions, right-angled connectors should not be used on the flue gas side of the boiler.

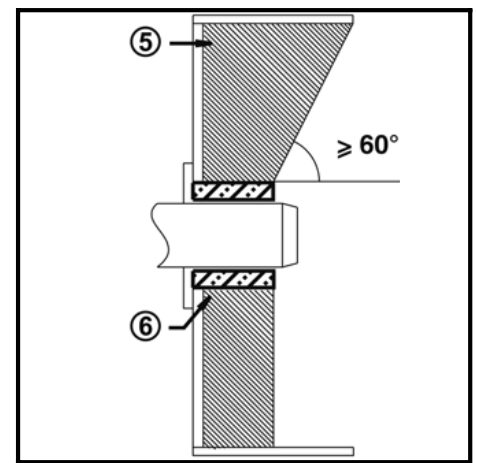
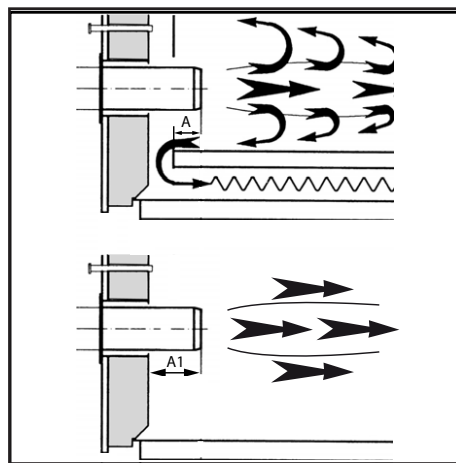
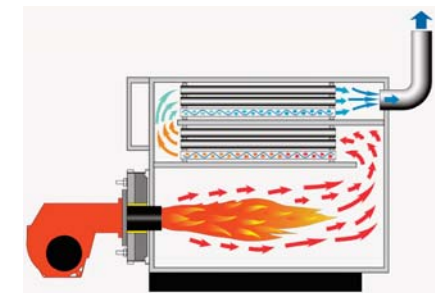
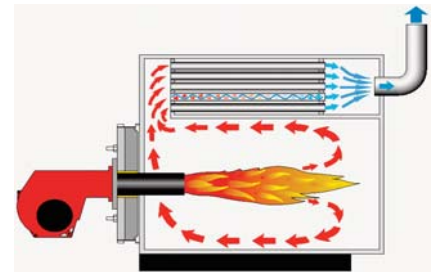
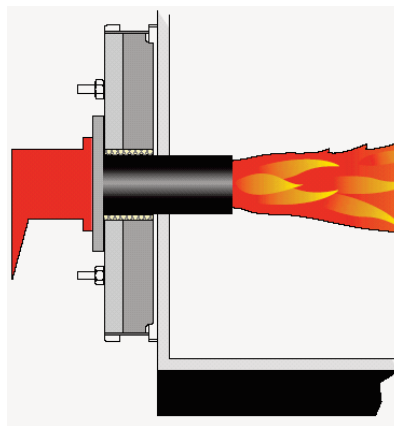

BURNER LINING

Check before burner installation:

1. Depending on the type of boiler (reverse flame or three pass) check the burner blast tube installation depth according to the data specified by the boiler manufacturer or consult the burner producer.
2. From the factory the nozzle for progressive version must be specified from the customer according to boiler output and combustion chamber geometry, otherwise we will select the nozzle for the 80% capacity of the burner.
3. Check the ignition electrodes and the nozzle on the burner head as per factory setting (see figures). The setting of the mixing and ignition unit according to the boiler output will be performed during commissioning procedure.
4. Check that the head is preset at 50%.

Position of the electrodes - nozzle installation

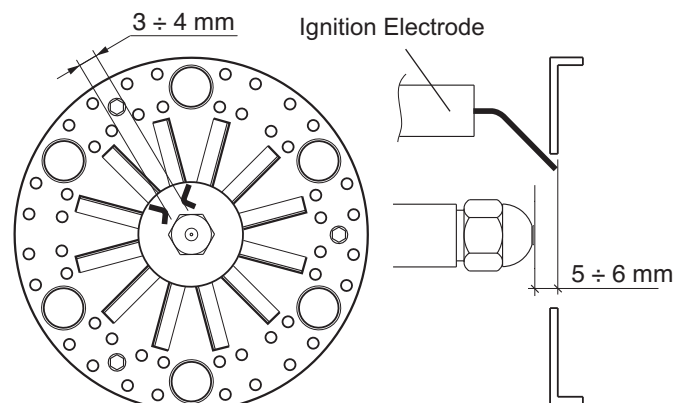

INSTALLATION

Oil connection

! **WARNING:** make sure that the feeding line is properly dimensioned and is in compliance with the local safety rules and code of practise in the country of installation

HYDRAULIC CIRCUIT LIGHT OIL FEEDING

- 176: oil pump
- 178: solenoid valve
- 184: output control valve
- 311: return oil pressure switch
- CV: check valve
- RL: return line
- VL: suction line
- VLO: working oil valve

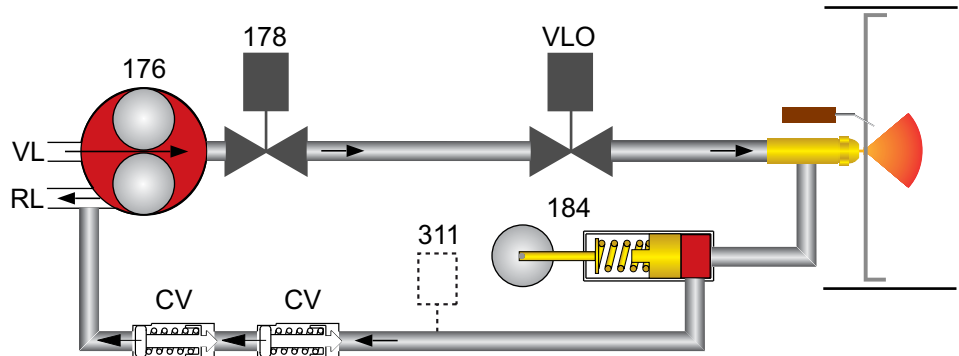

OIL PRESSURE CONTROL (FEED)

The feed pressure is controlled by means of the pressure regulator installed in the pump and should be set at 25. The pressure regulator is operated by turning its screw. Make sure to fill the pump with oil prior to taking into operation.

PUMP BLEEDING

Open the feed and return stop valves and ensure the ring line (if any) is in operation. Reduce the oil pressure at the pressure regulating valve. Turn on the pump by pressing the contactor. Check the pump for proper direction of rotation. Check for proper oil delivery and absence of leaks in the hydraulic oil system. For bleeding the pump open the pressure gauge connection, for example. When taking the burner into operation pro

ceed by gradually increasing the pressure to operating level (25 bar).

CHECKING THE PRESSURE (OIL SUCTION PRESSURE)

The maximum permissible vacuum is 0,4 bar. At higher vacuum levels the fuel oil will tend to separate air from oil which may lead to operating trouble. In the ring line mode of operation the recommended oil pressure is 2 bar.

OIL CONNECTION

Hoses are used for connection to the oil lines and stop valves. The hoses must be installed according to the applicable standards (relieved of tensile load, free of distortion) to avoid kinking and exclude the danger of breakage. Take care when mounting the oil lines to bring their ends as

close to the burners as possible and to arrange them in a way that the boiler door and the burner can be swing out without any obstruction.

Refer to the technical documentation for the line dimensions for the feed and return lines from the stop valves to the tank.

OIL FILTER

A filter must be installed upstream of the pump to protect the oil pressure pump and the hydraulic system.

INSTALLATION OPTIONS

- Two-line installation (separate feed and return lines without delivery pump).
- Ring line system (with delivery pump and gas-air separator).

LEGENDA

1. Inlet
2. Return
3. Bleed and pressure gauge port
4. Vacuum gauge port
5. Pressure adjustment
6. Nozzle outlet
7. Heater
8. Hose
9. Oil filter
10. Oil ball valve

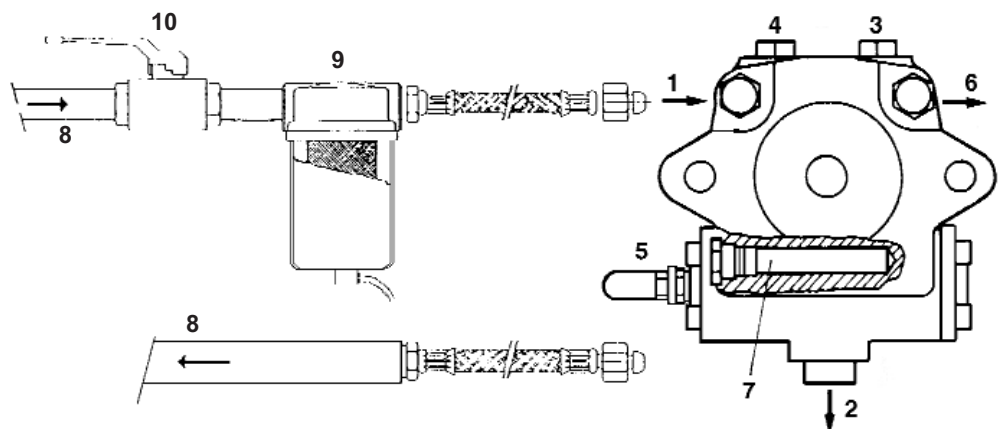

! **WARNING:** Check that the pump rotation is correct and before start up it has been pre-filled

INSTALLATION

Feeding and suction line for light oil

SUCTION LINE LENGTHS FOR PIPE SYSTEMS

- Two-pipe siphon feed system

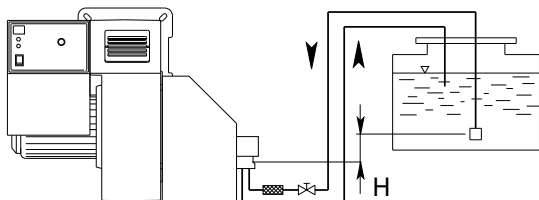

- Two-pipe lift system

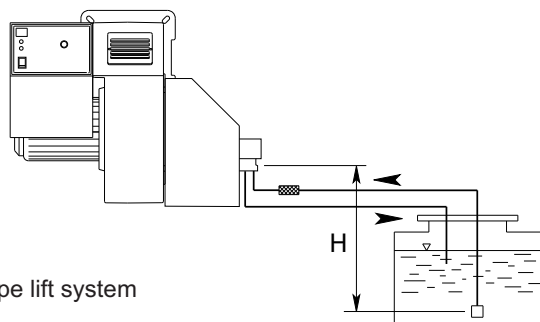

The burner is equipped with a self-priming pump which is capable of feeding itself within the limits listed in the table at the side.

H (m)	PIPE LENGTH (m) TA4	
	ø 20 mm	ø 30 mm
3	65	150
2,5	60	150
2	55	150
1,5	50	150
1	45	150
0,5	40	150
0	35	150
-0,5	28	150
-1	22	150
-1,5	12	150
-2	7	150
-2,5	--	150
-3	--	123
-3,5	--	78
-4	--	38

WARNING: To calculate the length of the pipework all the straight parts, curves, up and down pipes must be taken into consideration. The static suction height is the distance between the standing valve and the axis of the burner pump.

Negative pressure must not exceed 0,45 bar; if negative pressure is greater pump operation may become faulty, leading to an increase in mechanical noise and perhaps even breakage.

All oil ring installations must comply with the local safety rules existing in the country of installation

The pumps that are used can be installed both into single-pipe and double-pipe systems:

Single-pipe system: a single pipe drives the oil from the tank to the pump's inlet that deliver the pressurized oil to the nozzle and part of the oil not used goes back to the pump. With this single pipe the by-pass plug must be removed and the return port must be sealed with steel plug and washer.

Double-pipe system: this is the default solution from the factory. The return pipe send the excess oil from the pump to the tank. Depending on the type of pump used to change from a 1-pipe system to a 2-pipe-system, insert the by-pass plug (as for ccw-rotation referring to the pump shaft).

Note for commissioning: during commissioning, the filter, pipelines and pumps must be pre-filled with fuel oil and vented. The direction of rotation of the motor should be checked. When commissioning it must be ensured that pump never run dry.

NOZZLE SELECTION

Please refer to diagram to select Ecoflam recommended nozzle for the output that is required given the output necessary in the installation. Regular maintenance is highly recommended.

Nozzle has to be cleaned in petrol or paraffin and if filter or other parts are defective or damaged the nozzle must be replaced.

NOZZLE CHART IS AVAILABLE ON APPENDIX PAGE

SUNTEC TA

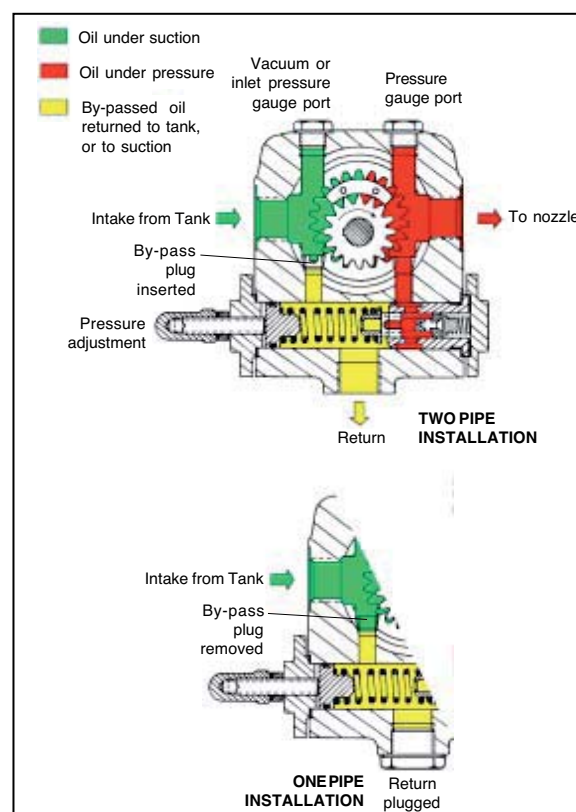

INSTALLATION

Gas line

CONNECTION DIAGRAM FOR BURNERS WITH SEPARATE PILOT (GAS TRAIN SIEMENS VGD...)

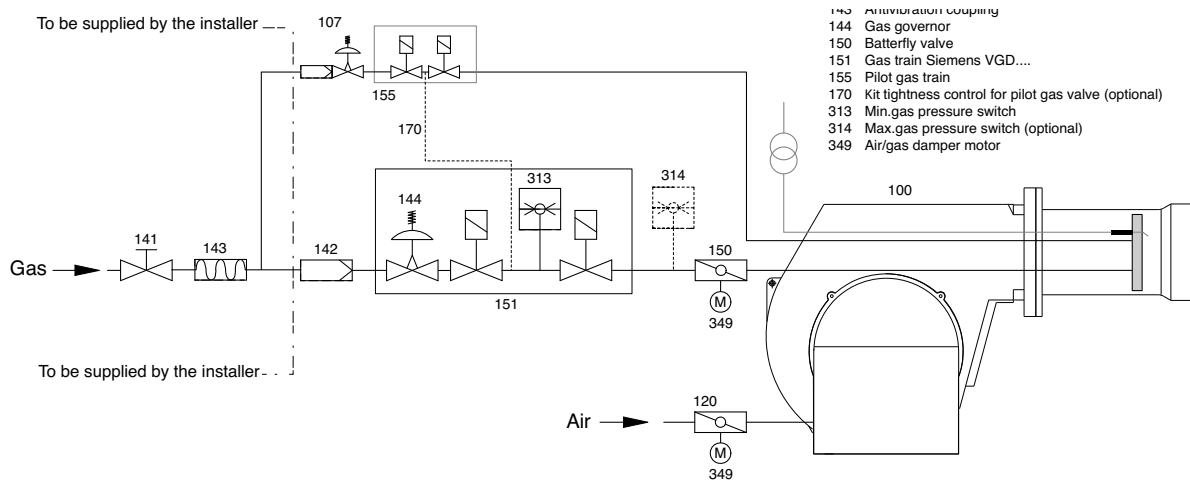

GAS VALVES AND INSTRUMENTS GROUP

The gas valves and instruments group used with the furnace will be selected according to the specific requirements to be met by a burner system.

The following factors must be taken into account:

- burner output
- furnace back pressure
- gas pressure loss of the burner head
- gas pressure losses of the gas valves and instruments group

NOTE: Only gas trains assembled by the burner manufacturer and approved in accordance with the burner test specifications. EN676 compulsory kit and accessories in order to comply to the safety regulations. Additional accessories and kits shall be installed by the installer in accordance to the local safety regulations and codes of practise.

GAS CONNECTION PRESSURE

A minimum connection pressure must be available upstream of the burner gas valve to ensure the proper functioning of the burner.

WARNING: *the total gas pressure loss must always be smaller than the available gas flow pressure.*

For the installation of the valves and instruments group take care to observe the mounting instructions supplied by their manufacturers (these are packed with the equipment).

The gas line installed to the burner must be dimensioned in accordance with the throughput rate and the available pressure.

For selecting the nominal bore “DN” of the gas valves and instruments group care should be taken to observe the flue resistance of the boiler and the gas pressure loss of the burner and valves and instruments group.

GAS VALVES AND INSTRUMENTS GROUP

The gas valves and instruments group can

be connected directly to the gas feed line.

Take care to observe the correct order of installation and direction of flow (arrow on housing).

Check the valves and instruments and connection pieces for absence of dirt particles and foreign matter before installation and initial operation. To provide effective conditions for start-up make sure the distance between the burner and the gas stop valve is as short as possible.

LEAK TEST

The gas line upstream of the burner gas valves and instruments group must be installed in accordance with the applicable regulations, checked for absence of leaks, vented and certified accordingly by the gas installation company. The screwed unions and flanged joints must be checked for proper tightness (by making a pressure test). The leak test must be made under pressure using approved foaming agents which do not cause corrosion. For steam boiler furnaces the result of the leak test must be duly certified.

VENTING

Prior to taking the burner into operation or after any repair work make sure to vent the complete gas feed line and the gas valves and instruments group into the open atmosphere (e.g. by means of a hose) taking care to avoid any hazards.

In no case should the gas line be vented into the heating or furnace chambers. Make use of a test burner to check the gas-carrying spaces are free from an inflammable gas mixture.

SUPPORT

The valves and instruments group must be supported with a telescopic jacking member or similar during and after installation (e.g. on filter and valve).

JOINT

It is recommended to provide an easy to disconnect joint (with planar sealing faces) to facilitate repair work on the boiler (furnace) and allow the boiler door to be swivelled out if required.

INSTALLATION

Pilot gas train, kit and accessories connection - head loss diagram

PILOT GAS TRAIN CONNECTION

The pilot gas train is already installed to the burner and shall be connected to the main gas supply line preferably with flexible pipe.

The pilot gas train is composed of n° 2 safety valves and n°1 gas governor and filter. Max inlet pressure 1 bar.

WARNING: Pilot gas train must be connected according to the drawing of the gas line.

GAS VALVES ADJUSTMENT

Note : the pilot valves are pre-adjusted in the factory. To increase or reduce the gas flow act on the gas governor.

GAS GOVERNOR ADJUSTMENT

The gas governor, with built-in filter, must be installed so as to stabilise the outlet gas pressure and to avoid that eventual impurities reach the gas valve. To increase gas pressure, remove the cover of governor and turn screw C. Unscrew screw C to reduce pressure, then fit the cover.

Note: the inlet gas pressure must not be higher than the specified max. gas pressure.

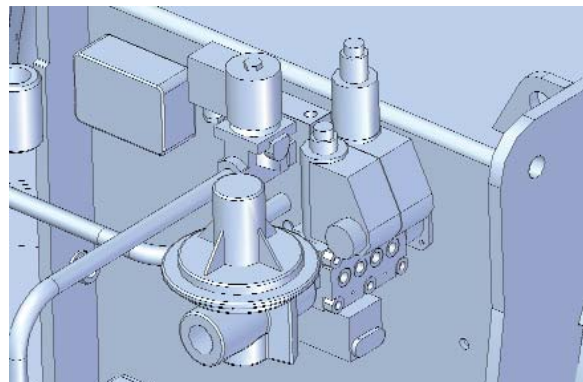
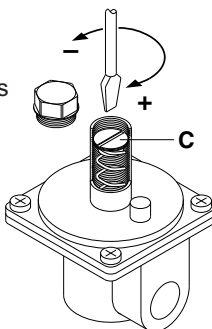



KITPRES... Maximum pressure switch assembly

Maximum pressure switch is provided as a kit and shall be assembled into the main gas train according to the instructions of the gas train separate manual.

KITMD-RWF50 PID regulator

All progressive burner can be turned modulation with the installation of the PID that regulates the output combined with a probe.

Modulation Kit	Max Pressure switch
KITMD-RWF50	KITPRES50
Probe-...	KITPRES150





GAS PRESSURE LOSS DIAGRAM: combustion head - platform 380

The diagram provides combustion head pressure loss. To have pressure loss combined with the different type of gas train you must refer to the pressure loss diagrams.

WARNING:

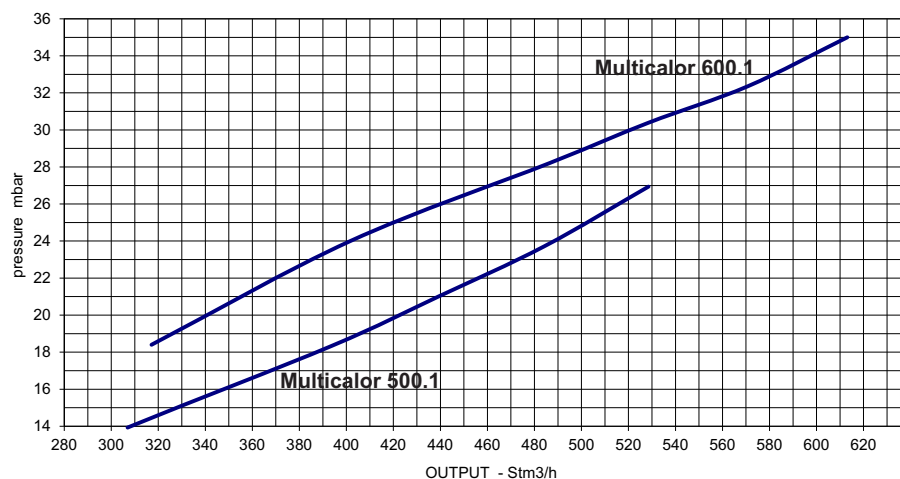
Note that the head loss diagram is only indicative and does vary depending on the setting of the head.



INSTALLATION

Gas pressure loss diagrams

! PRESSURE DROP includes: "COMBUSTION HEAD + GAS TRAIN + GAS GOVERNOR & FILTER" as per EN676 Standard. Back pressure of boiler (or other applications) must be added/included in order to have the total min pressure drop.

Burner	Gas train	Advisable gas governor & filter	Spring color	Inlet gas pressure MIN [mbar]	Inlet gas pressure MAX [mbar]	Diagram
BLU 5000.1 PR MULTICALOR 500.1 MULTIFLAM 500.1	VGD 40.125	no	yellow	33	500	3C
		FILTER DN 125		35	500	
	VGD 40.100	no	yellow	40	500	
		FILTER DN 100		45	500	
	VGD 40.080	no	yellow	60	500	
		FILTER DN 80		75	500	
	VGD 40.065	no	yellow	110	500	
		FILTER DN 65		140	500	
	VGD 20.503	no	yellow	210	500	
		FILTER 2"		250	500	

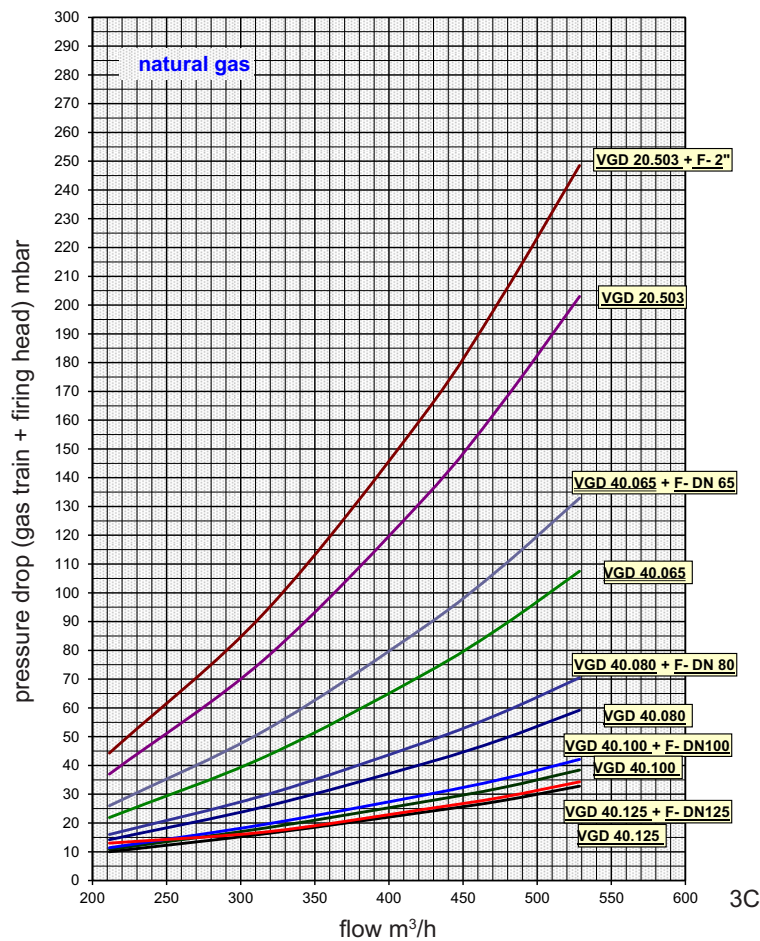

LEGENDA

Pf: Back pressure of furnace
 Pb: Pressure of burner (combustion head + complete gas train)
 Pin: Minimum inlet pressure

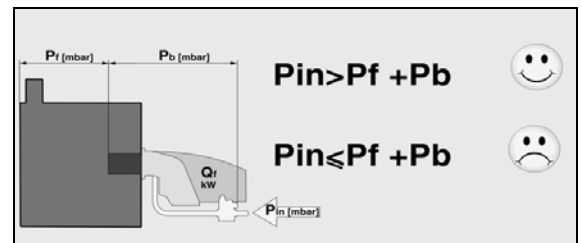

INSTALLATION

Gas pressure loss diagrams

! PRESSURE DROP includes: "COMBUSTION HEAD + GAS TRAIN + GAS GOVERNOR & FILTER" as per EN676 Standard. Back pressure of boiler (or other applications) must be added/included in order to have the total min pressure drop.

Burner	Gas train	Advisable gas governor & filter	Spring color	Inlet gas pressure MIN [mbar]	Inlet gas pressure MAX [mbar]	Diagram
BLU 6000.1 PR MULTICALOR 600.1 MULTIFLAM 600.1	VGD 40.125	no	yellow	45	500	4C
		FILTER DN 125		50	500	
	VGD 40.100	no	yellow	55	500	
		FILTER DN 100		60	500	
	VGD 40.080	no	yellow	80	500	
		FILTER DN 80		100	500	
	VGD 40.065	no	yellow	150	500	
		FILTER DN 65		180	500	
	VGD 20.503	no	yellow	275	500	
		FILTER 2"		340	500	

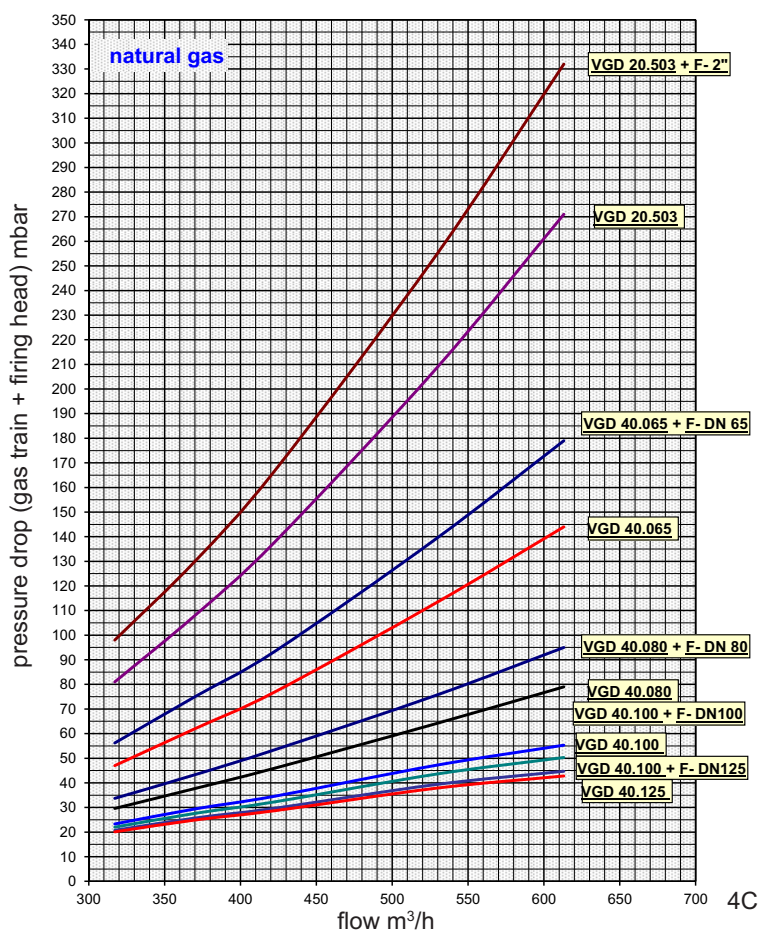

LEGENDA

Pf: Back pressure of furnace
 Pb: Pressure of burner (combustion head + complete gas train)
 Pin: Minimum inlet pressure

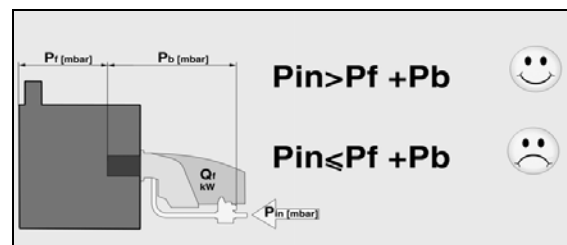

INSTALLATION

Electrical connections

! **WARNING:** Electrical wiring must be carried out with electrical supply disconnected and with burner switch in position OFF. Electrical supply must correspond to the one shown on the burner label.

APPLICABLE STANDARD

The electrical connection work comprising all the installation materials, terminals and earth connections must be carried out in accordance with the applicable regulations. For the electrical installation of the burner care must be taken to observe the circuit diagram made out for the furnace system.

The electrical connection of the burner and gas valves and instruments shall be entrusted to authorized specialists only.

NOTE: For the installation of the connection cables care must be taken to provide cable loops of sufficient length to allow for the swing-out of the boiler door and burner.

Make sure after the completion of the electrical connection work to check the wiring of the electrical system of the burner. This should include a check of the direction of rotation of the burner motor (fan).

GENERAL WARNINGS:

All applicable electrical safety regulations must be followed. Failure to correctly dimension the suitable input power and earth the equipment may cause damages to person and compromise the correct function of the burner therefore the electrical system shall be checked by qualified personnel.

The manufacturer declines all responsibility for modifications or connections different from those shown in the electrical scheme.

Adapters, multiple plugs and extension cables may not be used for the equipment's power supply.

An omnipolar switch in accordance with current safety regulations is required for the mains supply connection.

ELECTRICAL CONNECTION

1) of the burner

- Built-in electrical cabinet
Use cable gland in order to secure the required level of protection. All the links, power and control, are connected to the terminal block of the cabinet. Provide cables in sufficient length to secure the rotation of the burner body according to the assembly.

Check and adjust the size of the contactors and thermal relays and the wires section according to the motor and supply voltage specs.

ATTENTION: Wiring is not supplied.

2) of the gas train

- Connect the plugs pending to the valve: either on the cabinet, or on the coupling case on the body of the burner.

3) of the fuel oil motor-pump unit

- Connect the power circuit of the motor (hanging wires) to the plugs on the fuel oil valves.
- Check the rotary direction.

The burners are produced with connections suitable for power supply 230/400 V three-phase.

The burners with electric motors of an output lower or equal to 3 kW can be adapted to 230 V (please follow the instructions on the backside); motors with higher output can only work 400 V three-phase. In case of request of burners different from the above mentioned standard, it is recommended to make specific mention in the order.

Instructions: how to adapt electric motors of an output lower or equal to 3 kW to 230/400 V power supply

It is possible to change the voltage of the burner by operating as follows:
1. change the connection inside the electric box of the motor, from star to delta (see picture 1);
2. change the setting of the thermal relay, referring to the absorption values indicated in the motor nameplate. If necessary, replace the thermal relay with another one of suitable scale.
This operation is not possible on motors above 3 kW.
For more information, please contact the Ecoflam staff.

PROBES CONNECTION

ACTIVE PROBE CONNECTION (FOR MODULATING VERSION)

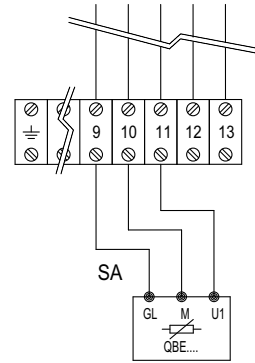

PASSIVE PROBE CONNECTION (FOR MODULATING VERSION)

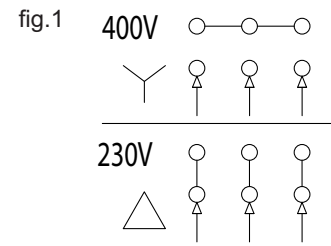
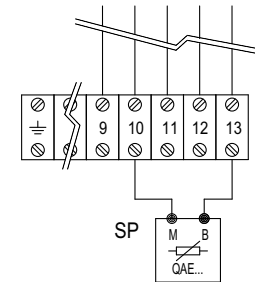

LEGENDA

SA: active probe
SP: passive probe

START-UP: CHECKING PROCEDURE

CHECKS BEFORE COMMISSIONING:

- That the burner is assembled in accordance with the instructions given here.
- Setting the combustion components.
- All electrical connections must be correct.
- Check the burner motor for correct direction of rotation.
- The heat generator must be ready for operation, and the operating regulations for the heat generator must be observed.
- The heat generator and heating system must be filled with water and the circulating pumps must be in operation.
- The temperature regulator, pressure regulator, low water detectors and any other safety or limiting devices that might be fitted must be connected and operational.
- The exhaust gas duct must be unobstructed and the secondary air system, if available, must be operational.
- An adequate supply of fresh air must be guaranteed.
- Make a test of the all gas-carrying elements for absence of leaks.
- Check tank, lines and oil pump are filled with oil and correct oil nozzle is fitted.
- With burner in starting position check that air damper is in "CLOSED" position.
- Check that control box is unlocked and in its original position.
- A standard-compliant measuring point must be available, the exhaust gas duct up to the measuring point must be free of leaks to prevent anomalies in the measurement results.

OIL START-UP

Open all shut-off valves of oil supply system.

- Set fuel selector switch to its "Oil"

position.

- Fill pump with oil.
- Mount pressure gauge in the feed line and return line.
- Mount the pressure gauge for checking the pump suction pressure.
- Make sure that the nozzle is size and mounted correctly.

Bleeding of oil system

Shortly start the burner and check for proper direction of rotation. Bleed the oil line and oil pump.

CAUTION: The hydraulic system has been filled with oil by the manufacturer. This may cause ignition trouble when initially operating the system. When starting the burner take care to increase the oil pressure slowly to the operating level.

GAS START-UP

NOTE: Adjust the gas unit according to the fuel oil unit. Set the fuel selector switch to its "Gas" position.

- Connect the measuring instruments for the gas head pressure on the test connection downstream of the gas damper and the air pressure on the burner test connection.
- Open the gas shut-off valve before the gas-armatures and test the gas pressure on the pressure gauge
- Set the "Manual-Automatic" selector switch to "Manual".

If the gas valves are tested for absence of leaks, this should be continued until a positive result is obtained. If a valve is found to leak, the program will not step forward to the control box.

The burner will start according to the program flow of the control box.

Prior to the initial fuel feed start make a functional test of the burner program flow:

Oil system:

- Open all shut-off valves of the oil supply system.
- The oil solenoid valve in the feed line disconnect on the terminal strip (see Circuit Diagram).
- Start burner and check program flow for correct start-up sequence:
 1. Fan starts.
 2. Pre-ventilating damper.
 3. Air pressure check.
 4. Partial-load air damper.
 5. Ignition.
 6. Valves open (disconnected valve remains closed).
 7. Shut-off upon trouble after expiry of safety period (see control box).
- Reconnect the valve.
- Unlock the control box.

Gas system:

- Shortly open the gas shut-off valve before the gas train until pressure is available and close again.
- Start burner and check program flow for correct start-up sequence:
 1. Fan.
 2. Pre-ventilation damper.
 3. Check air pressure.
 4. Partial-load damper.
 5. Ignition.
 6. Valves open.
 7. Shut-off upon trouble after expiry of safety period (see control box) or shut-off because of gas supply failure.
 7. The burner will either stop as the gas valves open (due to gas pressure decrease) or lock out at the end of the safety time.
- Unlock the control box.



Recording commissioning data

Test	n°1	n°2	n°3	n°4
Date				
Model				
Type gas				
Type oil				
Gas calorific value				
Oil calorific value				
Gas inlet pressure	mbar			
Adjustment gas pressure				
Volumetric gas flow rate	Nm ³ /h			
Burner output	min kW			
Burner output	max kW			
Flue gas temperature	C°			
Air temperature	C°			
CO ₂	%			
CO	ppm			
NOx	ppm			
Performance	%			
Corrective action				
Operator name				
Company				

EXHAUST GAS TEST

To ensure an economically efficient and trouble-free operation of the system it will be necessary to adjust the burner specifically in accordance with the furnace system. This is achieved by means of a fuel-combustion air compound control unit which adjusts the burner to ensure a proper combustion. Exhaust gas tests are required for this purpose.

The percentage CO₂ and O₂ and the exhaust gas temperature will have to be measured to determine the efficiency and combustion quality.

Prior to any measurement make sure to check the boiler and exhaust gas system for absence of leaks.

Secondary air will falsify the measured results

Check that the exhaust gases have a residual oxygen (O₂) content as low as possible and a carbon dioxide (CO₂) content as high as possible.

The carbon monoxide content of the exhaust gases must be below the currently applicable specifications in all load stages. In the fuel oil combustion mode the permissible soot number in the exhaust gas is not allowed to be exceeded

DETERMINING THE VOLUMETRIC GAS FLOW RATE

The thermal furnace output of a boiler (Q_F) is the amount of heat supplied with the gas in a unit of time.

When taking the burner into operation the volumetric fuel flow rate should be selected according to the nominal thermal capacity of the boiler.

Example:

Nom. thermal output	Q _N	1000 kW
Boiler efficiency	η _K	0,88
Calorific value of gas	H _u	9,1 kWh/m ³
Gas pressure	p _U	100 mbar
Barometer reading	p _{amb}	980 mbar
Gas temperature relative	t _{gas}	15°C
Gas temperature absolute	T	(t _{gas} +273)
Standard atmospheric pressure	p _n	1013 mbar

$$Q_F = \frac{Q_N}{\eta_K} = \frac{1000}{0,88} = 1136 \text{ kW}$$

Volumetric gas flow rate at STP:

$$V_{Bn} = \frac{Q_N}{H_u \cdot \eta_K} = \frac{1000}{9,1 \cdot 0,88} = 125 \text{ m}^3/\text{h}$$

Volumetric gas flow rate in operating condition:

$$V_{BB} = V_{Bn} \frac{T}{273} = \frac{p_n}{p_{amb} + p_u} = 125 \frac{273+15}{273} \frac{1013,25}{980+100} = 123,9 \text{ m}^3/\text{h}$$

Recommended combustion parameters

Fuel	Recommended (%) CO ₂	Recommended (%) O ₂
Natural gas	10 ÷ 9	3,1 ÷ 4,8
Light oil	13 ÷ 11,5	3,3 ÷ 5,3
Heavy oil	12,5 ÷ 11	4,2 ÷ 6,2

WARNING: if the installation is above sea level the output of the burner vary base on the diagram.

The regulation of the burner in this case shall take into account the reduced power of the burner due to the missing air.

Ratio between O₂- and CO₂- for natural gas H (CO₂max = 11,7%)

Ratio between O₂- and CO₂- for light oil EL (CO₂max = 15,40%)

Ratio between O₂- and CO₂- for heavy oil S (CO₂max = 15,60%)

$$O_2 = 21 \frac{CO_2\text{max} - CO_2\text{gem}}{CO_2\text{max}} = \%$$

CO₂ gem = % CO₂ measured on dry flue gases

Mean air pressure vs. altitude above sea-level

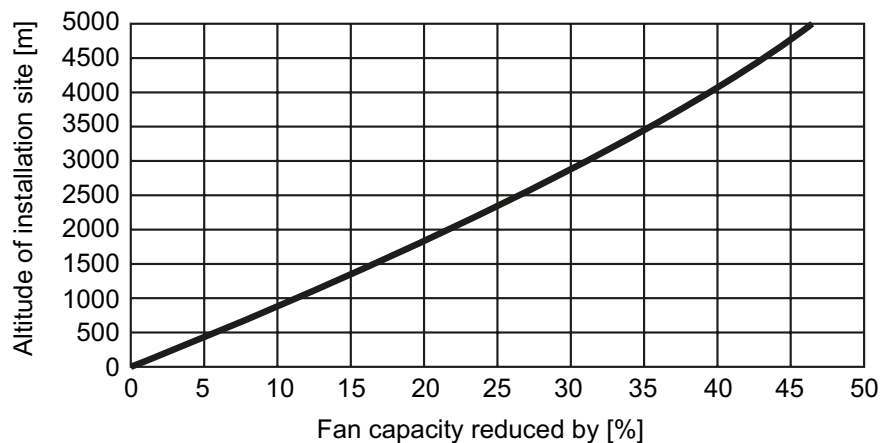

START-UP OIL SIDE

Fuel selection - Start-up

Select the oil operation in order to proceed with start up on the oil side. On the selector put the operation on minimum capacity.

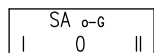

0=STOP
1=OIL
2=GAS



KMP - KMV contactor: check the oil pump motor and air fan motor rotation and keep KMP pressed till the oil circuit is loaded. If the rotation is not correct invert the two phases on the power supply.

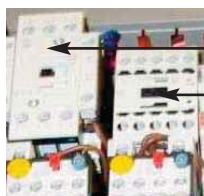

KMV

KMP

START UP THE BURNER

The control box starts the pre-purge cycle, the fan motor and the oil motor and opens the air flaps in full open position.

At the end of pre-purging, the control box drives the servomotors into the ignition position and starts the ignition transformer.

After a few seconds the control box opens the oil valve and starts the flame. After the flame stabilisation the control box drives the servomotor in the low flame.

In case of faulty ignition, the control box switches the burner into safety condition, in such a case you must rearm the burner.

Gradually increase burner output from the low flame to the high flame and set oil servomotor curve in order to have a stable flame. Refer to LAMTEC manual attached.

Adjusting the maximum air flow rate

Air and Oil adjustment are accomplished through LAMTEC parameters setting. Refer to LAMTEC manual attached.

Firing head setting

The firing head is pre-adjusted at the 50% from the factory. The setting fully open enables to reach the full power of the burner and full close to reach the minimum power of the burner. The optimal position depends on the output that we need to reach but the default setting shall be modified only when you are not able to reach the suggested combustion value by adjusting the air flow in the maximum flame.

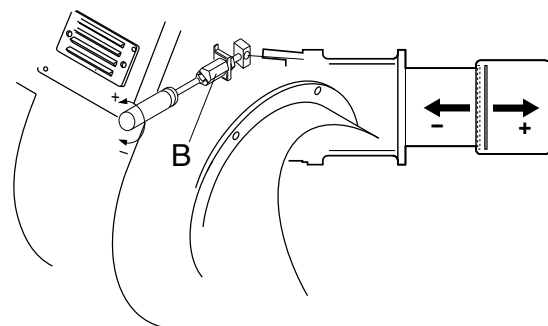

START-UP OIL SIDE

Adjusting the maximum oil flow rate

Put the selector on the oil operation. Adjust the oil pressure reading the value on the return manometer / pressure gauge according to the nozzle tables provided in the appendix. Oil adjustment is accomplished through LAMTEC parameters setting. Refer to LAMTEC manual attached.

NOTE: the pump pressure is set from the factory at the pressure required nozzle pressure required as per table of nozzle selection in appendix. If the output required is different from the one set from the factory the pressure can be adjusted according to the instruction below.

Servomotor LAMTEC - Air damper motor pre-setting

Air adjustment is accomplished through LAMTEC parameters setting. Refer to LAMTEC manual attached.



Adjusting the pump pressure

- 1 - INLET
- 2 - RETURN
- 3 - BLEED AND PRESSURE GAUGE PORT
- 4 - VACUUM GAUGE PORT
- 5 - PRESSURE ADJUSTMENT
- 6 - TO NOZZLE

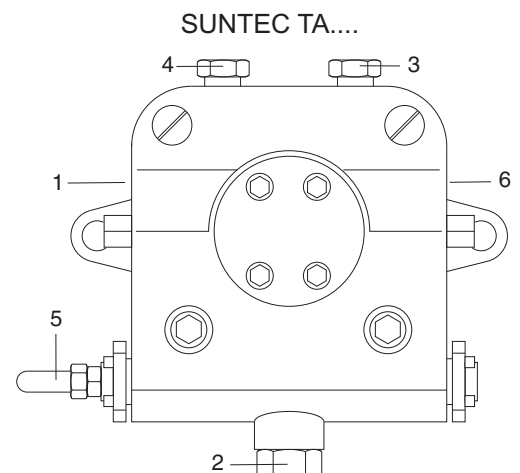

The pump pressure is set at a value of 22-25 bar during the testing of burners.

Before starting the burner, bleed the air in the pump through the gauge port.

Fill the piping with light oil to facilitate the pump priming. Start the burner and check the pump feeding pressure.

In case the pump priming does not take place during the first pre-purging, with a consequent, subsequent lock-out of the burner, rearm the burner's lock-out to restart, by pushing the button on the control box.

If, after a successful pump priming, the burner locks-out after the prepurging,

due to a fuel pressure drop in the pump, rearm the burner's lock-out to restart the burner.

Do never allow the pump working without oil for more than three minutes.



NOTE: before starting the burner, check that the return pipe is open. An eventual obstruction could damage the pump sealing device.

START-UP OIL SIDE

Adjusting the intermediate burner capacity

Oil adjustment is accomplished through LAMTEC parameters setting. Refer to LAMTEC manual attached.

WARNING: the variable profile of the cam shall have a normal proportional curvature in order to have good combustion values and reduce its mechanical stress breakdown.

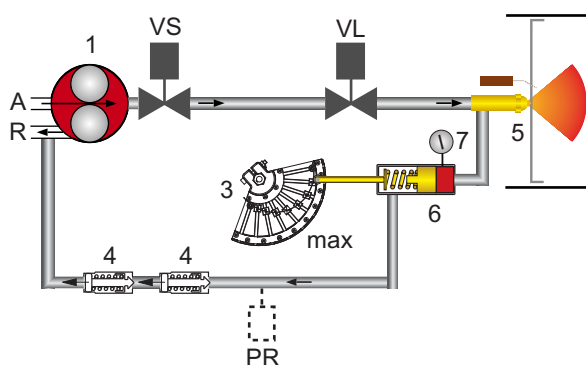

WARNING: Once the setting on the oil has been completed make sure that you close the manometer – pressure switch tap.

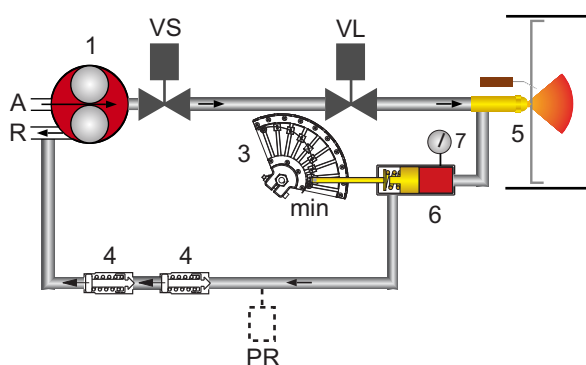

LEGENDA

- 1. Oil pump
- VS. Oil safety valve
- 3. Adjusting cam
- 4. Check valve
- VL. Working valve
- PR. Pressostat (optional)
- 5. Nozzle
- 6. Pressure regulator
- 7. Manometer – pressure gauge

START-UP GAS SIDE

Fuel selection - Start-up

Select the gas operation in order to proceed with start up on the gas side.

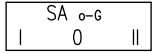

0=STOP
1=OIL
2=GAS

! KMV contactor: check the air fan motor rotation. If not correct invert the two phases on the power supply.

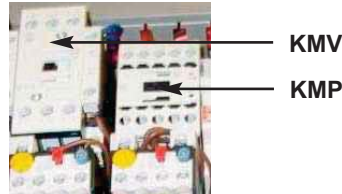

START UP THE BURNER

The control box starts the pre-purge cycle, the fan motor and opens the air flaps in full open position.

At the end of pre-purging, the control box drives the servomotor into the ignition position and starts the ignition transformer.

After a few seconds the control box opens the pilot valves and starts the pilot flame.

After the flame stabilisation the control box opens the main valves and the burner goes in the low flame and the pilot switch off.

In case of faulty igniton, the control box switches the burner into safety condition, in such a case you must rearm the burner.

Gradually increase burner output from the low flame to the high flame and set gas servomotor curve in order to have a stable flame. Refer to LAMTEC manual attached.

Adjusting the maximum air flow rate

Air and Gas adjustment are accomplished through LAMTEC parameters setting. Refer to LAMTEC manual attached.

Firing head setting

The firing head is pre-adjusted at the 50% from the factory. The setting fully open enables to reach the full power of the burner and full close to reach the minimum power of the burner. The optimal position depends on the output that we need to reach but the default setting shall be modified only when you are not able to reach the suggested combustion value by adjusting the air flow in the maximum flame.

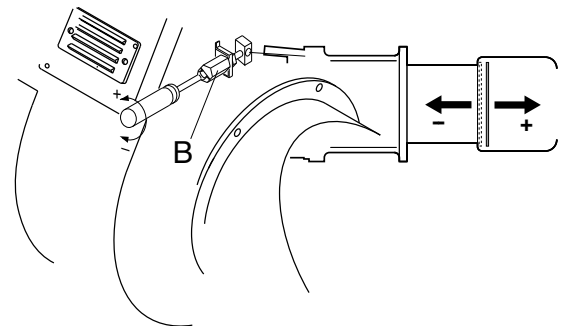

Servomotor LAMTEC - Air damper motor pre-setting

Air adjustment is accomplished through LAMTEC parameters setting. Refer to LAMTEC manual attached.

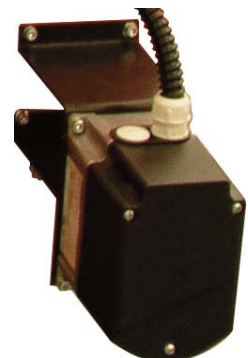

START-UP GAS SIDE

Adjusting the intermediate burner capacity

Gas adjustment is accomplished through LAMTEC parameters setting. Refer to LAMTEC manual attached.

WARNING: the variable profile of the cam shall have a normal proportional curvature in order to have good combustion values and reduce its mechanical stress breakdown.

Pressure switch adjustment

AIR PRESSURE SWITCH CALIBRATION

The air pressure switch is provided for monitoring the pressure of the combustion air fan. Unscrew screws A and B and remove cover C.

After the air and gas setting you have to calibrate the air switch with the burner working on the low flame by slowly turning the relative knob clockwise until the burner locks out. Read the value and then decrease it by 15%.

Set the pressure switch to the minimum by turning knob D to position 1.

Start the burner and keep in low flame running, while checking that combustion is correct. Through a small cardboard, progressively obstruct the air intake until to obtain a CO₂ increase of 0,5±0,8% or else, if a pressure gauge is available, connected to pressure port E, until reaching a pressure drop of 1 mbar (10 mm of W.G.).

Slowly increase the adjustment value of the air pressure switch until to have the burner lockout. Remove the obstruction from the air intake, screw on the cover C and start the burner by pressing the control box rearm button.

WARNING: the air pressure switch shall prevent the air pressure to go below 80% from the adjustment value in order to prevent the CO in the fumes to exceed 1% (10000 ppm). Using the analyser try to close the air inlet and check that the burner locks out before exceeding CO value of 1% in the fumes.

MIN GAS PRESSURE SWITCH

The gas pressure switch has the function to check that the gas pressure before the gas valve does have the minimum pressure to make the burner running correctly.

Unscrew off and remove cover M. - Set knob N to a value equal to 60% of gas nominal feed pressure (i.e. for natural gas nom. pressure = 20 mbar, set knob to a value of 12 mbar; for LPG nom. pressure of G30/G31- 30/37 mbar, set knob to a value of 18 mbar).

MAX GAS PRESSURE SWITCH (KIT)

The maximum gas pressure switch has the function to check that the gas pressure after the gas train and before the head does not exceed the pre-set limits.

Max gas pressure switch: it is available as a kit for different pressure.

Air pressure switch

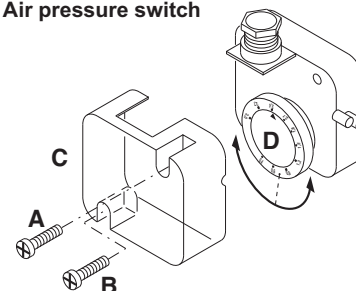

Gas pressure switch

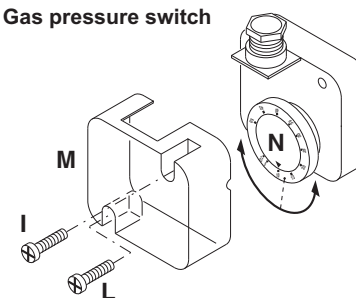

MAINTENANCE PROGRAM



Burner and boiler servicing must only be carried out by authorised qualified personnel at least once a year. Depending on the type of installation, shorter maintenance intervals may be necessary. The system operator is advised to take out a maintenance contract to guarantee regular servicing.
WARNING: Use original spare parts.

SAFETY WARNINGS:

1. Turn off the power supply and protect the system from accidental start-up
2. Cut oil and gas supply
3. Make sure there is no residual power in the system and that the actions in points 1 and 2 have been completed
4. Before opening the burner casing, ensure that the fan motor has stopped completely

Failure to observe any of these instructions will result in the risk of death or injury!

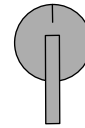
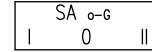

0=STOP
1=OIL
2=GAS

WORKS RECOMMENDED AS PART OF ANNUAL BURNER MAINTENANCE:

- Emergency stop button function check
- Check burner start characteristics
- Run burner test and input measurement in the boiler room
- Clean the combustion components and replace defective parts if necessary
- Check the combustion head components and make sure that all components are in good condition otherwise replace them
- Replace ignition electrodes and nozzle if necessary and check their correct position after any intervention
- Flame monitor and automatic combustion control unit function check
- Clean the fan wheel and the housing and grease rotating parts if necessary
- Clean the oil filter cartridge with gasoline periodically and check the tightening of the O rings, replace them if necessary
- Perform visual inspection of gas lines in the boiler room and check the gas flow
- Clean the gas filter cartridge with air periodically, replace it if necessary
- After the cleaning of the components of the gas train perform the leakage test
- Make visual inspection of the burner's electrical components and eliminate malfunctions if necessary
- Burner safety devices function check (air pressure/gas pressure switches)
- Commissioning the burner and correct the adjustment values if necessary

NOTES ON REASSEMBLING: Perform the described step in reverse order and make sure to refit components as they were originally assembled and the system is free from leaks. Use only original spare parts.

DRAW UP A MEASUREMENT REPORT ACCORDING TO THE LOCAL REGULATION AND CODES OF PRACTISE OF THE COUNTRY

EXHAUST GAS LOSS

Exhaust gas loss by way of free heat will occur as a result of the temperature difference between the fuel-air mixture entering the furnace chamber and the gases discharged. Any increase in the excess of air and the resultant higher exhaust gas volume will cause the exhaust gas loss to rise. The exhaust gas loss can be calculated as follows:

$$q_A = (t_A - t_L) \frac{A_1}{CO_2} + B$$

- q_A = exhaust gas loss [%]
- t_A = exhaust gas temperature [°C]
- t_L = combustion air temperature [°C]
- CO_2 = volumetric content of carbon dioxide [%]

	Light oil EL	Heavy oil S	Natural gas	Town gas	LPG
A1	0,50	0,490	0,370	0,350	0,420
B	0,007	0,007	0,009	0,011	0,008

Example

Data measured in natural gas mode:
 CO₂ content of exhaust gases: 10,8%
 Exhaust gas temperature: 195°C
 Air intake temperature: 22°C

The exhaust gas loss can be calculated as follows:

$$q_{Af} = (195-22) \left(\frac{0,37}{10,8} + 0,009 \right) = 7,48\%$$

Data measured in fuel oil mode:
 CO₂ content of exhaust gases: 12,8%
 Exhaust gas temperature: 195°C
 Air intake temperature: 22°C

The exhaust gas loss can be calculated as follows:

$$q_{Af} = (195-22) \left(\frac{0,49}{12,8} + 0,007 \right) = 7,83\%$$

MAINTENANCE PROGRAM

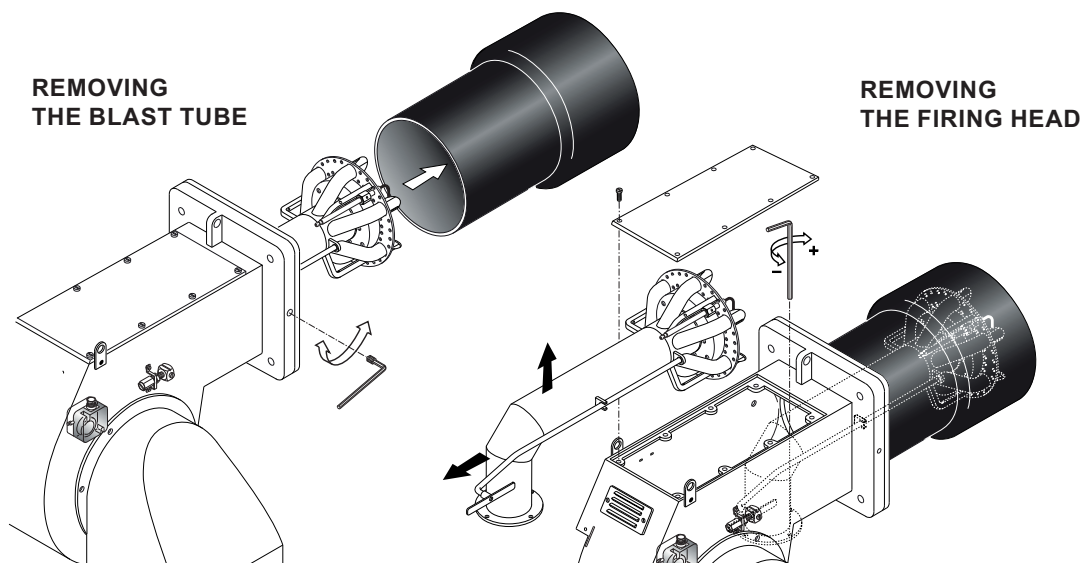

POSITION OF ELECTRODES

ATTENTION:

to remove the nozzle use the suitable box wrench taking care to not damage the electrodes. Check the position of the electrodes after any intervention as wrong position could cause ignition troubles.

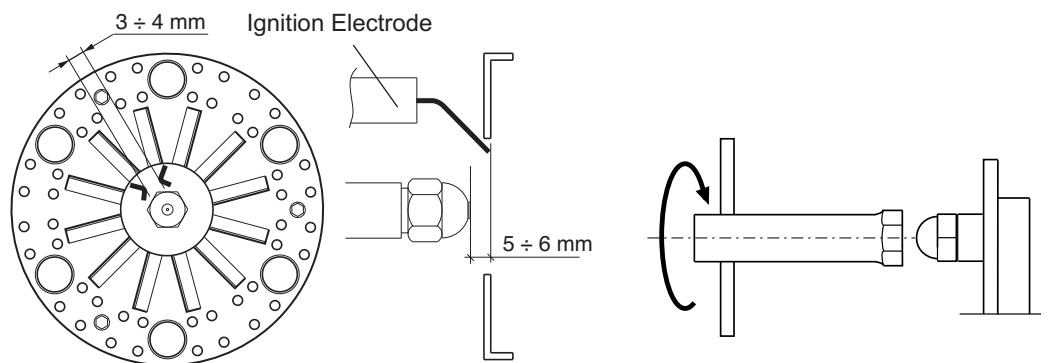

GAS FILTER CLEANING - GAS PILOT FILTER CLEANING



ATTENTION: Periodically clean oil cartridge with gasoline and the gas filter cartridge with air and replace them if it is necessary!



Check and clean the gas filter in the pilot gas valve

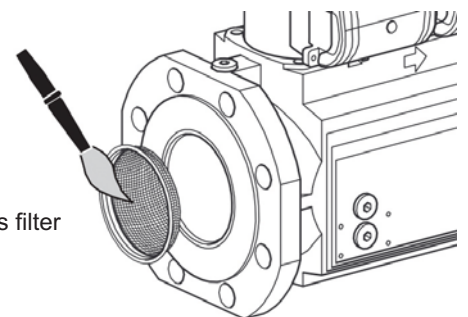

TROUBLESHOOTING INSTRUCTIONS

For Setting and Error Lists refer to LAMTEC manual attached.

OPERATING TROUBLE

In case of operating trouble it should be checked whether the system is in proper working order.

Make a check for the following:

1. Availability of fuel.
Availability of gas in the line at sufficiently high pressure.
Availability of fuel oil in the tank (for dual fuel burner).
Correct position of fuel selector switch.
2. Availability of electric power in the burner system.

3. Proper functional order and setting of all control and safety instruments such as temperature controller, safety limiter, water failure cut-out, electrical limit switches, etc. If the trouble is not found to be due to any of the above-mentioned points it will be necessary to test the burner functions very carefully.

Prevailing conditions:
The burner will be found to be out of operation and in faulty and interlocked position.

Proceed with searching for the cause of the trouble and eliminate it. Unlock the control box by pressing the fault eliminate key and start the burner.

Do not press the fault eliminate key longer than 10 seconds.

The start-up program will be initiated and should be carefully monitored.

The possible cause of the fault may be quickly found by reference to the fault indicator of the control box and watching the start-up and operating program.

APPENDIX

Display - Control box

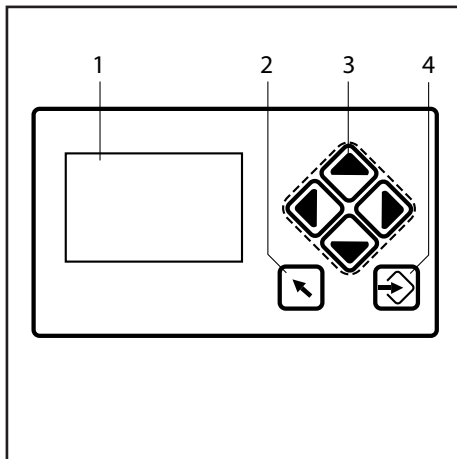

- 1 Display
- 2 Back key
- 3 Cursor keys
- 4 Enter key

Display
The display shows in pictogram:

- the menu structure
- operating status
- parameters
- error messages



Jump to previous window.



You navigate in the menu using cursor keys. You use 'left' and 'right' keys to move step by step in a selected row. At the end of the selected row the cursor jumps down to the next row, if possible. In a multiline menu use 'up' and 'down' keys to switch to other rows. To display parameters, switch between various fields.



Press ENTER to call up a menu on the start screen. Select a sub-menu in the menu window. Transfer setting values by pressing ENTER key in a parameter window. Use a flushing, red ENTER key to release a fault interlocker. If the ENTER key is permanently lit red, a fault with an automatic restart is displayed.



Always switch off the power supply before installing or removing the control unit. Do not attempt to open or carry out repairs on the control unit.



Modulate with LCM

Ecoflam burners equipped with LCM are set up to receive the Siemens RWF modulator so they have:

- quick connector for electrical connection of the RWF kit.
- bridge on terminals 22, 23, 24.
- BT 300 set with parameter 0040 to 0 (zero). It means that there is no LCM and, if there is, it is not used as a modulator.

To use LCM as a modulator and not to install the RWF kit accordingly:

- remove bridges on terminals 22, 23, 24.
- connect on 22, 23, 24 a thermoresistance Pt 100 or Pt1000 setting the dip switch 4 accordingly.
- set BT300 with parameter 0040 to 1.

Refer to LAMTEC manual attached.

APPENDIX

Fluidics nozzle chart

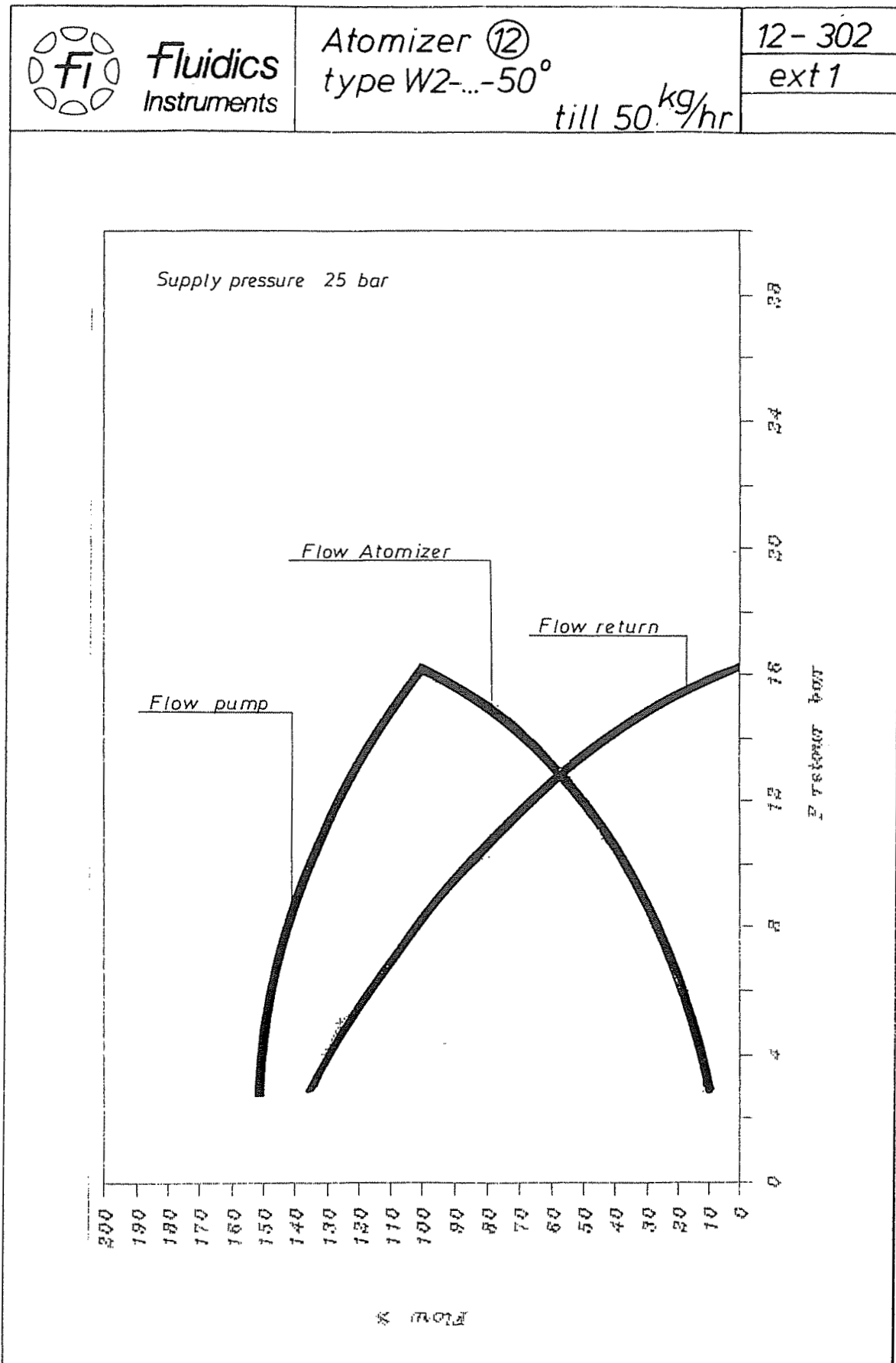

APPENDIX

Fluidics nozzle chart

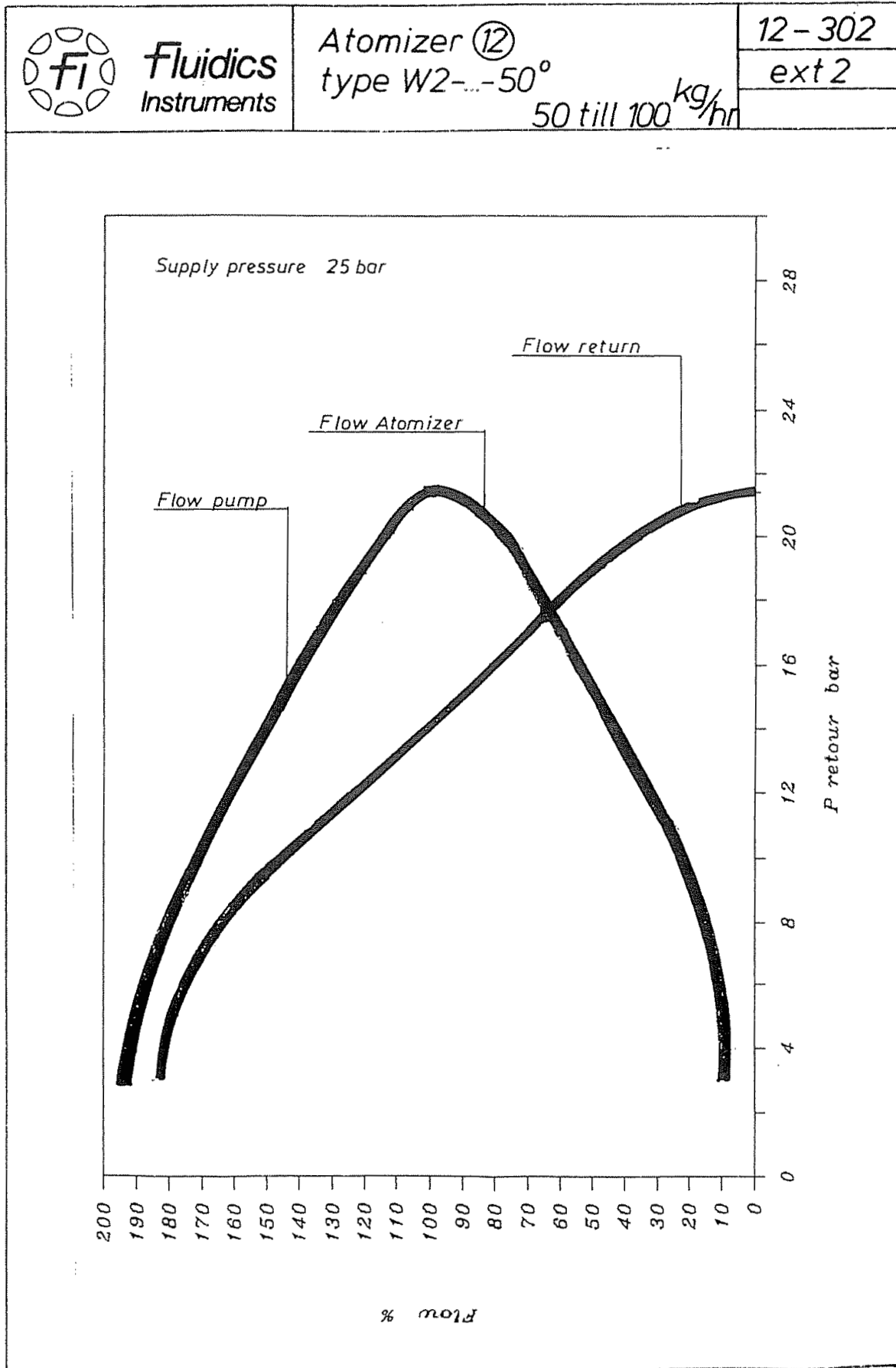

APPENDIX

Fluidics nozzle chart

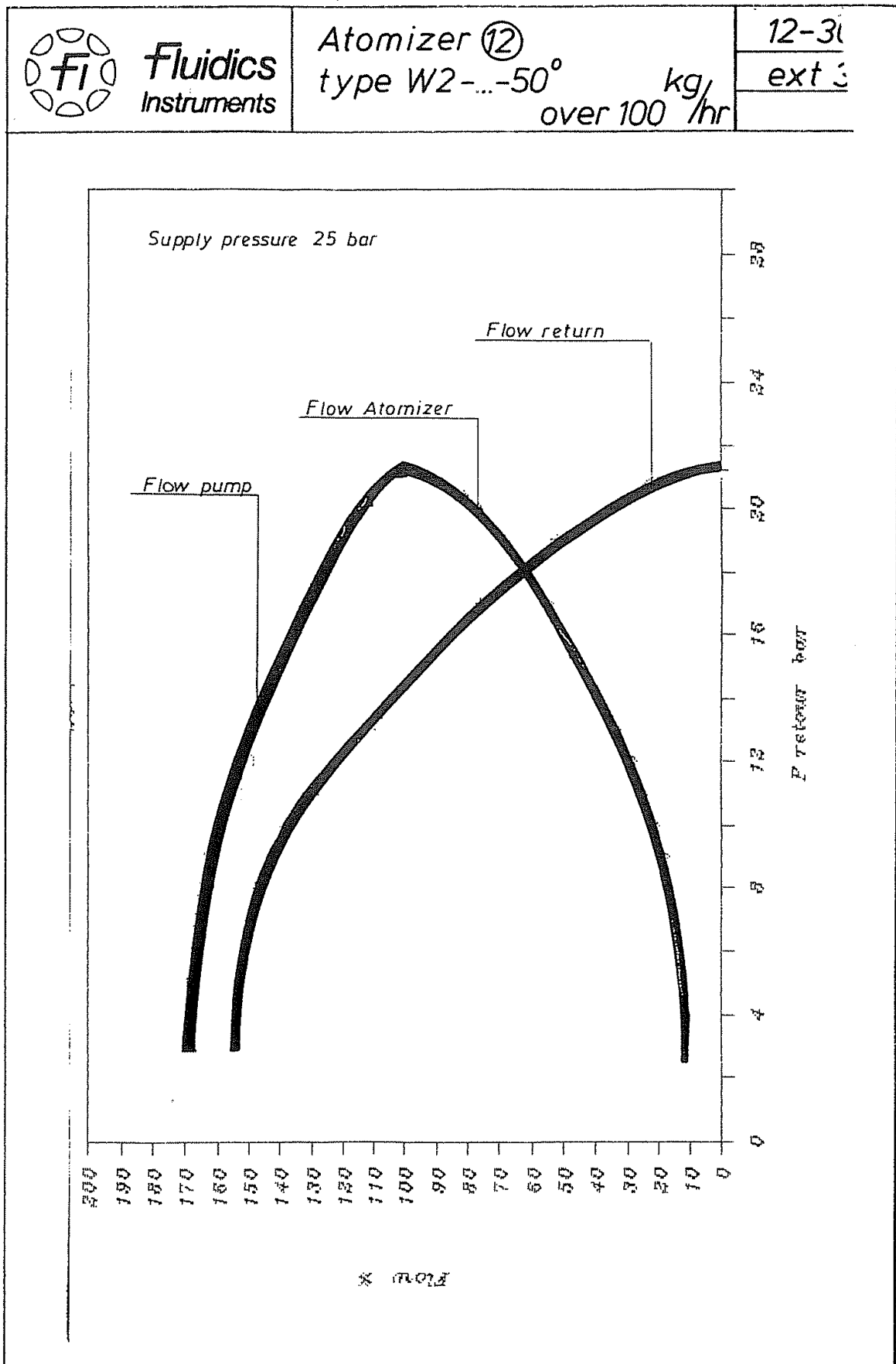

APPENDIX

Bergonzo nozzle tables

Return pressure [bar]

Nozzle kg/h	Bar	3	4	5	6	7	8	9	10	11	12	13	14	15	16	17	18	19	20	21	22	23	24	25	26	27	28	29	
100	A	20	28	29	29	30	31	32	34	36	38	40	45	48	52	60	70	90											
100	B	20	250	250	250	248	245	240	235	220	200	190	180	170	155	135	115	90											
100	A	25	32	33	33	34	34	35	36	37	38	40	42	43	45	47	49	52	58	62	72	90							
100	B	25	290	280	275	273	270	268	265	255	248	240	225	215	200	190	180	170	160	140	125	110							
100	A	30	33	33	33	33	34	34	34	35	36	37	38	41	44	46	48	50	52	54	59	64	69	75	80	90	100	120	
100	B	30	310	310	308	306	304	302	300	295	290	285	280	275	265	255	245	235	225	210	200	190	180	170	150	140	120		
125	A	20	38	39	40	41	42	43	44	45	49	53	57	61	65	69	73	95	100										
125	B	20	300	300	295	285	275	275	265	245	230	215	200	185	174	153	140	120											
125	A	25	41	42	43	44	45	46	47	48	49	51	53	55	58	60	64	68	72	80	88	105	120						
125	B	25	330	330	330	325	320	315	310	305	295	290	285	280	265	240	230	220	200	190	170	150	130						
125	A	30	43	43	43	44	44	45	45	46	47	48	50	52	54	54	58	62	64	67	70	75	78	81	90	98	110	130	
125	B	30	360	359	358	357	356	355	355	350	345	340	335	330	320	310	300	290	280	270	255	240	220	205	190	175	155	135	
150	A	20	47	48	50	52	54	56	58	61	64	68	72	78	85	92	100	110											
150	B	20	280	279	278	277	276	275	268	260	240	230	215	190	175	160	145	125											
150	A	25	52	52	53	54	55	56	57	58	60	64	68	72	76	80	85	90	97	105	118	128	142						
150	B	25	325	325	310	300	300	290	285	280	275	270	265	260	255	240	230	220	210	190	170	160							
150	A	30	57	56	55	54	54	55	57	58	59	60	62	65	68	72	75	80	84	88	93	99	105	112	120	130	145	160	
150	B	30	340	340	340	338	336	334	332	330	328	324	320	315	310	300	290	280	270	260	250	240	230	220	210	190	180	160	
175	A	20	55	57	59	62	64	66	68	72	75	80	82	90	95	102	115	130	150										
175	B	20	285	280	275	270	270	265	265	260	255	250	245	240	230	200	185	170	150										
175	A	25	60	61	62	63	64	65	66	68	70	72	78	80	82	85	92	98	105	110	120	140	160						
175	B	25	330	330	330	330	325	325	320	315	310	300	295	280	270	260	252	245	235	225	200	180							
175	A	30	67	68	69	70	71	72	73	74	75	76	77	79	80	82	85	90	92	95	100	105	110	118	125	140	160	180	
175	B	30	360	360	360	355	355	350	345	345	340	340	335	330	330	325	320	310	300	290	280	270	260	250	240	225	200		
200	A	20	57	58	59	60	62	65	68	72	78	82	92	100	110	125	140	160	180										
200	B	20	350	350	350	345	345	340	330	325	300	285	275	260	245	220	200	190											
200	A	25	65	66	67	68	70	71	73	75	78	81	86	90	95	100	108	115	122	135	150	170	190						
200	B	25	400	400	400	400	390	385	380	375	370	365	360	350	340	330	320	300	285	270	260	245	220						
200	A	30	66	67	68	68	69	70	71	72	75	78	80	82	88	92	98	102	108	113	118	125	130	140	155	175	225		
200	B	30	460	460	460	460	458	456	452	448	440	430	420	405	390	380	370	360	350	342	335	325	315	300	290	275	260	245	
225	A	20	65	68	70	72	76	79	84	88	91	94	102	110	118	125	140	160	200										
225	B	20	420	410	405	400	390	382	376	370	350	345	335	320	300	280	265	250											
225	A	25	72	73	74	75	75	76	79	82	85	88	91	95	100	105	115	120	130	145	160	180	225						
225	B	25	475	468	460	460	460	455	450	440	430	420	410	400	380	365	345	325	315	300	275	260							
225	A	30	78	78	78	79	79	80	82	84	86	88	90	91	94	98	100	110	115	118	125	130	135	145	155	175	200	240	
225	B	30	510	510	505	505	503	500	495	490	485	480	475	470	465	455	445	435	425	410	392	380	370	360	350	325	300	275	
250	A	20	76	78	80	84	88	90	94	105	110	118	125	135	145	160	180	220											
250	B	20	425	415	408	403	400	380	375	365	355	345	330	315	300	285	275	250											
250	A	25	87	88	88	89	91	94	96	100	104	108	112	122	132	142	155	162	175	180	210	225	250						
250	B	25	480	475	475	470	465	465	460	455	445	435	425	415	405	382	365	350	345	330	320	300	280						
250	A	30	89	90	90	92	94	95	96	98	102	106	109	112	118	124	136	144	155	160	170	180	190	210	225	235	265		
250	B	30	520	518	518	515	512	510	510	508	504	500	490	480	470	460	450	440	430	420	410	390	375	360	340	320	300	275	

A = nozzle output

Output [kg/h]

Supply: 25 bar

B = pump output

APPENDIX

Bergonzo nozzle tables

Return pressure [bar]

Nozzle kg/h	Bar	3	4	5	6	7	8	9	10	11	12	13	14	15	16	17	18	19	20	21	22	23	24	25	26	27	28	29
275 A	20	80	84	88	92	96	98	104	112	118	125	135	142	152	170	190	230											
275 B	20	475	475	470	466	460	445	430	420	405	390	370	360	350	330	310	285											
275 A	25	92	93	94	95	96	98	100	105	110	118	120	130	138	145	155	164	178	195	210	240	265						
275 B	25	525	525	525	520	515	510	505	500	495	490	480	470	460	450	440	425	400	375	350	325	300						
275 A	30	105	106	107	108	109	110	112	116	118	120	125	130	135	138	142	148	154	160	170	180	190	210	225	250	280		
275 B	30	600	600	600	600	600	600	595	590	585	580	570	565	543	530	515	500	490	475	465	450	440	425	400	380	360	330	
300 A	20	85	88	90	94	98	100	105	110	115	125	135	145	155	170	190	225	275										
300 B	20	480	480	480	476	470	465	460	450	435	415	400	375	365	350	325	300	280										
300 A	25	100	100	100	102	104	106	108	110	113	116	120	125	135	145	155	165	180	200	225	255	310						
300 B	25	550	550	545	540	535	530	520	510	500	490	482	475	463	450	440	430	415	390	370	350	310						
300 A	30	105	106	107	108	110	112	114	116	118	120	124	128	132	136	140	146	152	162	175	182	195	210	230	260	290	340	
300 B	30	625	625	625	620	615	610	605	600	590	580	570	560	550	540	530	520	510	495	480	465	450	430	410	390	375	350	
325 A	20	95	96	97	98	100	103	106	110	120	130	140	150	165	200	240	260											
325 B	20	550	545	540	535	530	520	510	500	480	460	440	420	400	375	355	325											
325 A	25	108	107	108	109	110	112	114	116	118	125	132	141	150	160	170	180	200	225	250	280	330						
325 B	25	630	630	630	625	620	615	610	605	600	585	570	565	535	520	500	480	460	440	410	385	360						
325 A	30	115	115	116	117	118	119	120	122	126	130	135	140	147	152	160	170	180	190	200	210	225	242	260	280	310	330	
325 B	30	720	715	710	705	702	700	700	690	680	670	655	620	610	600	580	570	550	520	500	480	460	440	420	400	380		
350 A	20	105	107	108	109	110	115	118	125	135	145	155	170	190	215	240	275											
350 B	20	590	580	570	560	550	540	530	500	480	465	450	440	400	375	360	340											
350 A	25	120	122	124	126	128	132	134	136	138	140	145	150	155	165	175	185	200	225	255	275	350						
350 B	25	620	620	620	615	614	612	610	605	600	595	575	565	550	530	510	490	470	450	410	380	360						
350 A	30	125	125	127	129	131	133	135	138	141	143	145	150	155	160	168	174	184	195	210	225	245	265	280	325	370		
350 B	30	710	710	708	704	703	702	700	690	680	670	660	650	640	630	615	600	580	560	540	520	500	475	440	425	400		
375 A	20	110	114	118	127	134	137	140	145	152	162	170	180	195	210	250	290											
375 B	20	600	590	580	575	560	550	540	530	515	500	485	465	450	425	400	370											
375 A	25	130	130	130	132	134	136	138	140	146	150	155	160	170	180	195	210	230	250	275	320	375						
375 B	25	690	690	680	680	670	660	650	630	620	610	600	580	560	540	520	500	485	465	450	425	400						
375 A	30	135	136	137	138	139	140	142	144	148	151	155	160	166	172	180	190	200	210	225	235	250	270	300	340	370		
375 B	30	790	780	770	760	750	740	730	720	710	700	690	682	674	666	658	650	632	615	600	575	545	530	525	480			
400 A	20	130	135	140	145	150	155	160	170	180	190	205	220	240	263	330	370											
400 B	20	650	650	650	640	630	620	610	600	580	560	540	500	475	420	420	380											
400 A	25	130	135	140	145	150	155	160	170	178	185	195	202	212	225	250	270	290	320	340	375	400						
400 B	25	725	725	720	720	715	710	705	700	690	670	640	630	600	580	565	550	525	480	470	450	425						
400 A	30	152	153	154	155	157	162	165	170	176	180	190	200	210	220	230	245	260	270	285	300	325	365	400	425	450		
400 B	30	845	840	835	830	825	820	815	810	805	800	790	780	760	740	715	690	660	650	620	600	580	560	540	520	500		
425 A	20	120	125	130	135	140	145	150	165	175	185	210	230	250	275	300	350											
425 B	20	700	690	680	670	660	650	635	615	600	575	550	525	505	465	435	400											
425 A	25	145	146	147	148	149	150	154	157	160	170	180	190	210	225	245	265	280	320	360	400							
425 B	25	800	800	800	790	780	770	760	750	725	700	685	670	650	625	600	575	550	510	480	450							
425 A	30	150	150	149	148	147	146	145	148	154	160	168	177	185	195	205	225	238	250	270	290	310	325	360	380	450		
425 B	30	880	875	870	865	860	855	850	840	830	820	810	800	780	760	740	720	700	685	670	650	610	590	570	550	510		

Supply: 25 bar

A = nozzle output

B = pump output

Output [kg/h]

APPENDIX

Bergonzo nozzle tables

Return pressure [bar]

Nozzle kg/h	Bar	3	4	5	6	7	8	9	10	11	12	13	14	15	16	17	18	19	20	21	22	23	24	25	26	27	28	29					
450	A	20	130	135	140	145	150	158	165	175	185	200	210	230	255	280	320	375															
450	B	20	700	690	680	670	660	650	630	615	600	580	550	520	490	460	425	400															
450	A	25	145	145	148	151	154	158	162	165	170	180	190	200	220	240	255	280	310	350	390	450											
450	B	25	810	808	806	803	800	785	767	750	730	710	690	670	650	625	600	580	560	530	500	475											
450	A	30	155	156	157	158	160	162	165	170	175	180	187	194	200	210	220	230	240	260	275	290	310	340	375	420							
450	B	30	890	885	880	875	870	865	860	850	840	830	820	810	800	790	780	770	740	710	690	670	630	610	560	520	500						
475	A	20	145	148	152	158	165	170	180	195	200	210	230	250	275	300	340	410															
475	B	20	740	735	730	720	710	700	680	660	640	620	490	560	530	500	475	450															
475	A	25	140	162	164	166	168	170	175	180	188	195	205	215	225	245	265	280	305	340	380	480											
475	B	25	850	845	840	835	830	820	810	800	790	780	760	740	720	700	675	650	620	580	540	510											
475	A	30	170	171	172	173	174	176	177	178	180	186	194	200	210	225	235	245	255	275	285	305	330	365	400	460	540						
475	B	30	910	909	908	907	906	904	902	900	890	880	865	850	835	820	800	785	765	750	725	700	675	660	635	600	560						
500	A	20	150	155	160	167	174	180	190	205	220	235	250	275	300	350	400																
500	B	20	740	730	720	710	700	685	665	650	630	610	590	570	550	520	490																
500	A	25	174	175	178	180	185	190	195	200	210	220	230	245	250	265	285	315	350	380	435	510											
500	B	25	845	840	835	830	825	820	815	810	800	780	765	750	725	700	675	650	625	600	580	550											
500	A	30	180	185	190	195	200	206	212	218	225	238	242	250	262	275	288	300	316	332	350	375	400	425	475	520							
500	B	30	945	940	935	930	925	920	915	910	905	900	880	865	850	835	815	800	775	750	725	700	685	650	630	610							

Supply: 25 bar

Output [kg/h]

A = nozzle output

B = pump output

APPENDIX

Pumps and pressure regulators

PUMP SUNTEC TA TECHNICAL DATA

Note: All TA models are delivered for two-pipe system (by-pass plug fitted in vacuum gauge port).

For one-pipe system, the by-pass plug must be removed and the return port sealed by steel plug and washer.

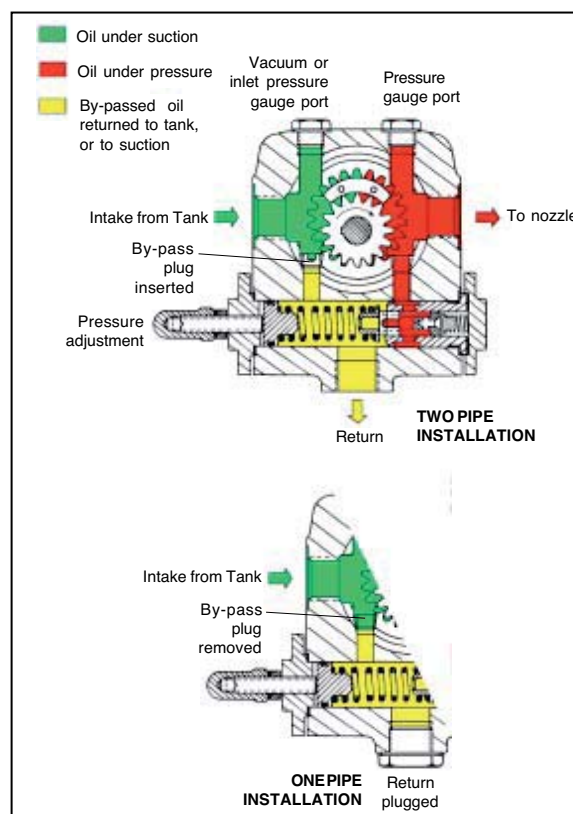
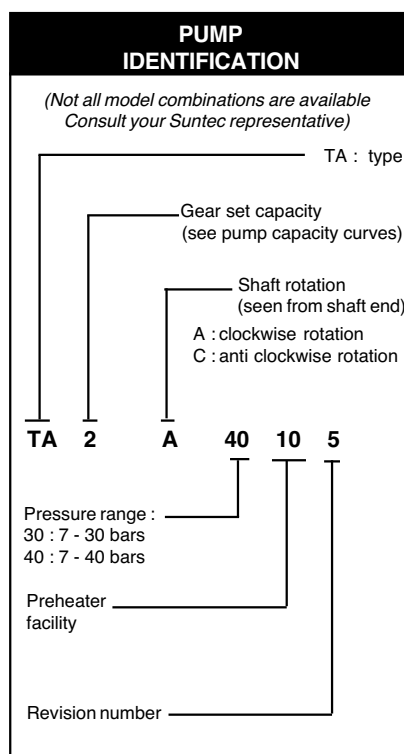

General

Mounting	Flange mounting	
Connection threads	Cylindrical according to ISO 228/1	
Inlet end return	G 1/2"	
To nozzle	G 1/2"	
Pressure gauge port	G 1/4"	
Vacuum gauge port	G 1/4"	
Shaft	Ø 12 mm	
By-pass plug	Inserted in vacuum gauge port for 2 pipe system; to be removed with a 3/16" Allen key for 1 pipe system	
Weight	5,4 kg (TA2) 6 kg (TA4)	5,7 kg (TA3) 6,4 kg (TA5)

Hydraulic data

Nozzle pressure ranges	30 : 7 - 30 bars 40 : 7 - 40 bars
Delivery pressure setting	30 bars
Operating viscosity	4 - 450 cSt
Oil temperature	0 - 140°C max. in the pump
Inlet pressure	light oil : 0,45 bars max. vacuum to prevent air separation from oil heavy oil : 5 bars max.
Return pressure	light oil : 5 bars max. heavy oil : 5 bars max.
Rated speed	3600 rpm max.
Starting torque	0,3 N.m

Choice of heater

Cartridge	Ø 12 mm
Fitting	according to DIN 40430, NFC 68190 (N°9 elec.)
Rating	80-100 W

Pump capacity

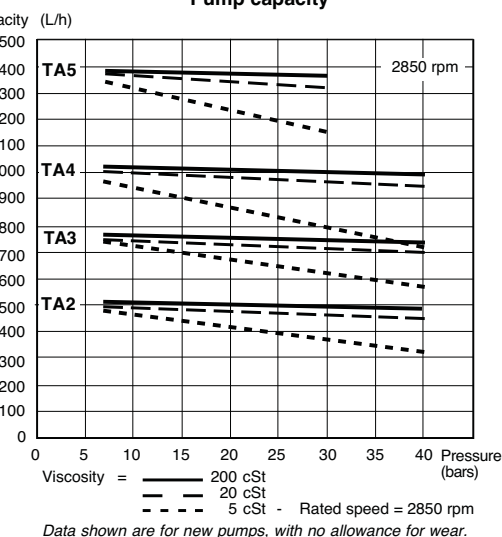

APPENDIX

Electrical diagrams

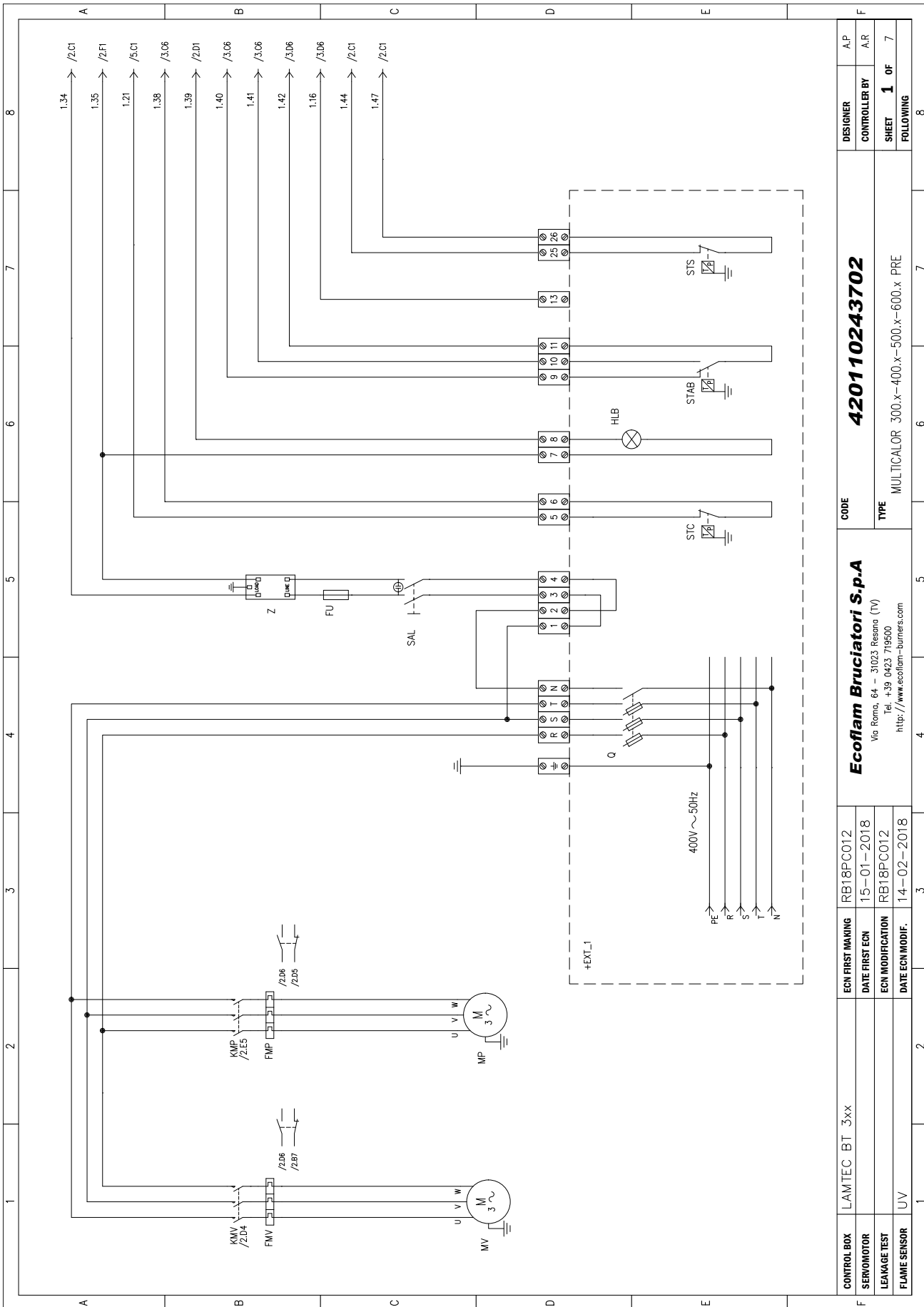

CONTROL BOX	LAMTEC BT_3xx	ECON FIRST MAKING	RB18PC012	CODE	420110243702		
SERVO MOTOR		DATE FIRST ECON	15-01-2018	Ecoflam Bruciatori S.p.A.			
LEAKAGE TEST		ECON MODIFICATION	RB18PC012	Via Roma, 64 - 31023 Resana (TV)			
FLAME SENSOR	UV	DATE ECON MODIF.	14-02-2018	Tel. +39 0423 719500			
				http://www.ecoflam-burners.com			
				TYPE	MULTICALOR 300.x-400.x-500.x-600.x PRE		
				DESIGNER	A.P.		
				CONTROLLER BY	A.R.		
				SHEET	1 OF 7		
				FOLLOWING	8		

APPENDIX

Electrical diagrams

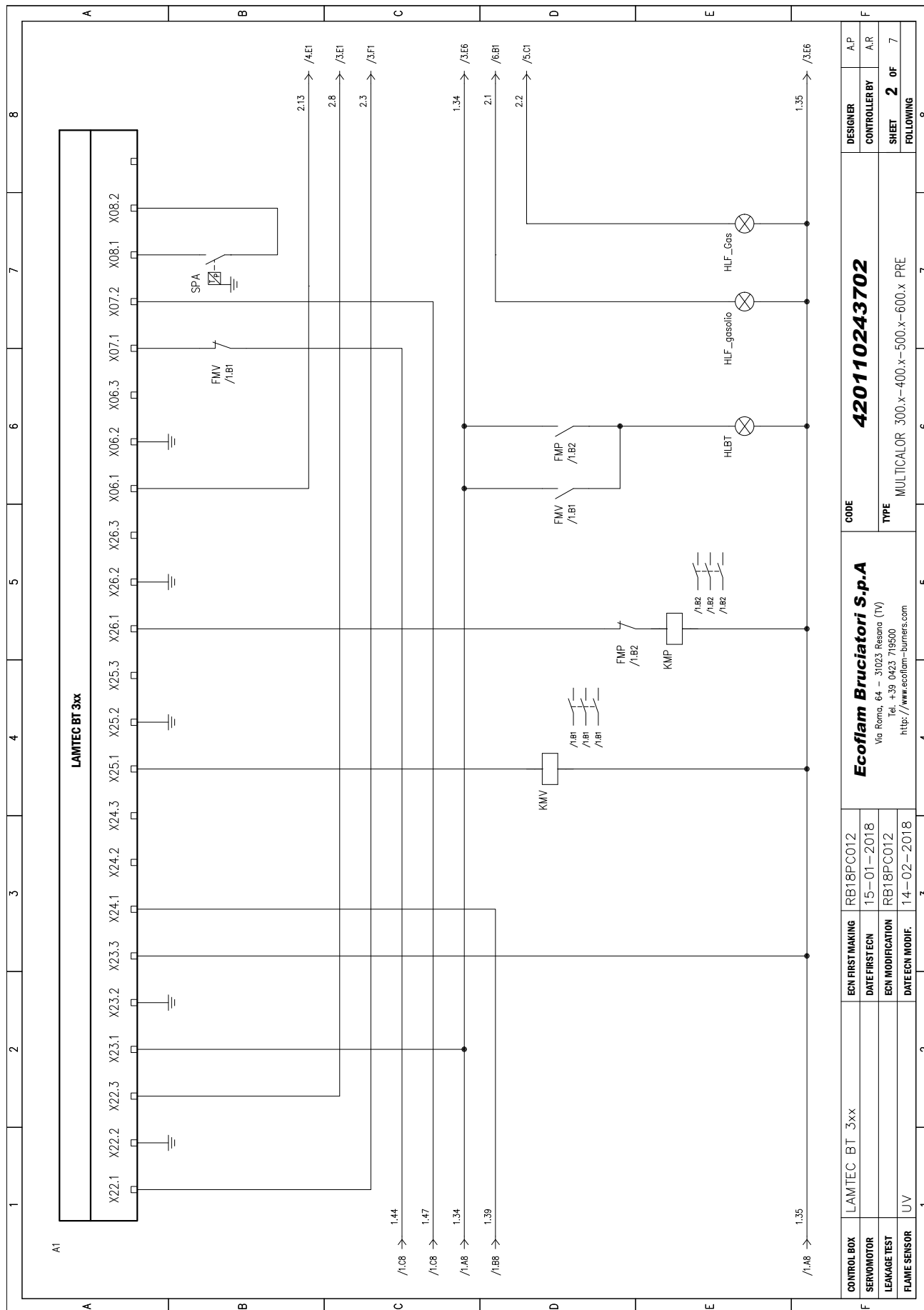

CONTROL BOX	LAMTEC BT 3xx	ECON FIRST MAKING	RB18PC012	CODE	420110243702	
SERVO MOTOR		DATE FIRST ECN	15-01-2018	DESIGNER	A.P.	
LEAKAGE TEST		ECON MODIFICATION	RB18PC012	CONTROLLER BY	A.R.	
FLAME SENSOR	UV	DATE ECN MODIF.	14-02-2018	SHEET	2	OF 7
				FOLLOWING	8	
				TYPE	MULTICALOR 300.x-400.x-500.x-600.x PRE	
				Ecoflam Bruciatori S.p.A. Via Roma, 64 - 31023 Resana (TV) Tel. +39 0423 719500 http://www.ecoflam-burners.com		

APPENDIX

Electrical diagrams

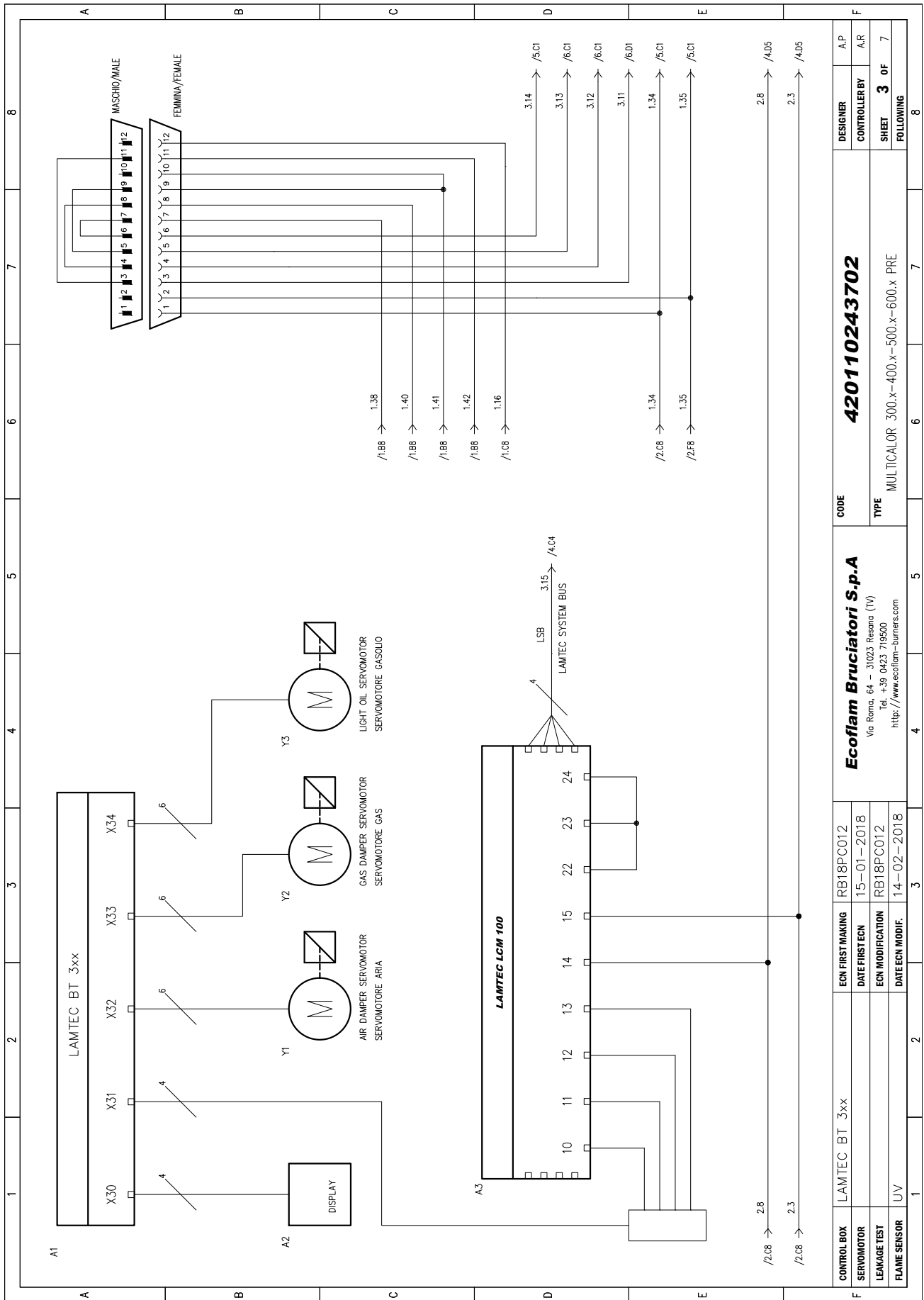

CONTROL BOX		LAMTEC BT 3xx		EON FIRST MAKING		RB18PC012		DESIGNER		A.P	
SERVOMOTOR				DATE FIRST ECN		15-01-2018		CONTROLLER BY		A.R	
LEAKAGE TEST				ECN MODIFICATION		RB18PC012		SHEET		3 OF 7	
FLAME SENSOR		UV		DATE ECN MODIF.		14-02-2018		FOLLOWING		8	
CODE				420110243702				TYPE			
Ecoflam Bruciatori S.p.A				MULTICALOR 300.x-400.x-500.x-600.x PRE							
Vo. Remo, 64 - 31023 Resana (TV)				Tel. +39 0423 719500				http://www.ecoflam-burners.com			

APPENDIX

Electrical diagrams

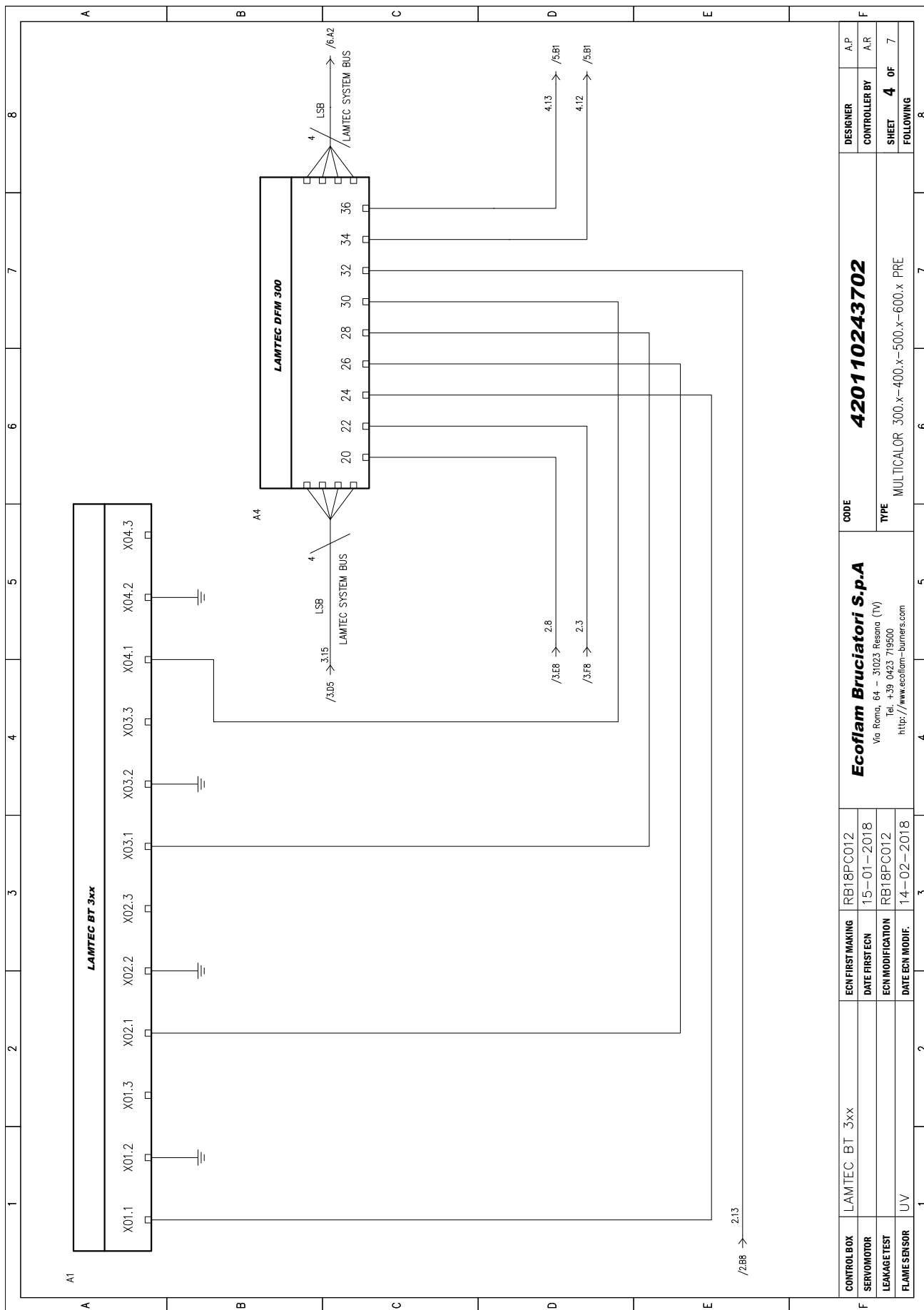

CONTROL BOX		LAMTEC BT 3xx		ECON FIRST MAKING		RB18PC012		CODE		DESIGNER		A.P.	
SERVOMOTOR				DATE FIRST ECN		15-01-2018		Ecoflam Bruciatori S.p.A		CONTROLLER BY		A.R.	
LEAKAGE TEST				ECON MODIFICATION		RB18PC012		420110243702		SHEET		4 OF 7	
FLAME SENSOR		UV		DATE ECN MODIF.		14-02-2018		TYPE		FOLLOWING		8	
								MUL TICALOR 300.x-400.x-500.x-600.x PRE					
								Via Roma, 64 - 31023 Resana (TV)					
								Tel. +39 0423 719500					
								http://www.ecoflam-burners.com					

APPENDIX

Electrical diagrams

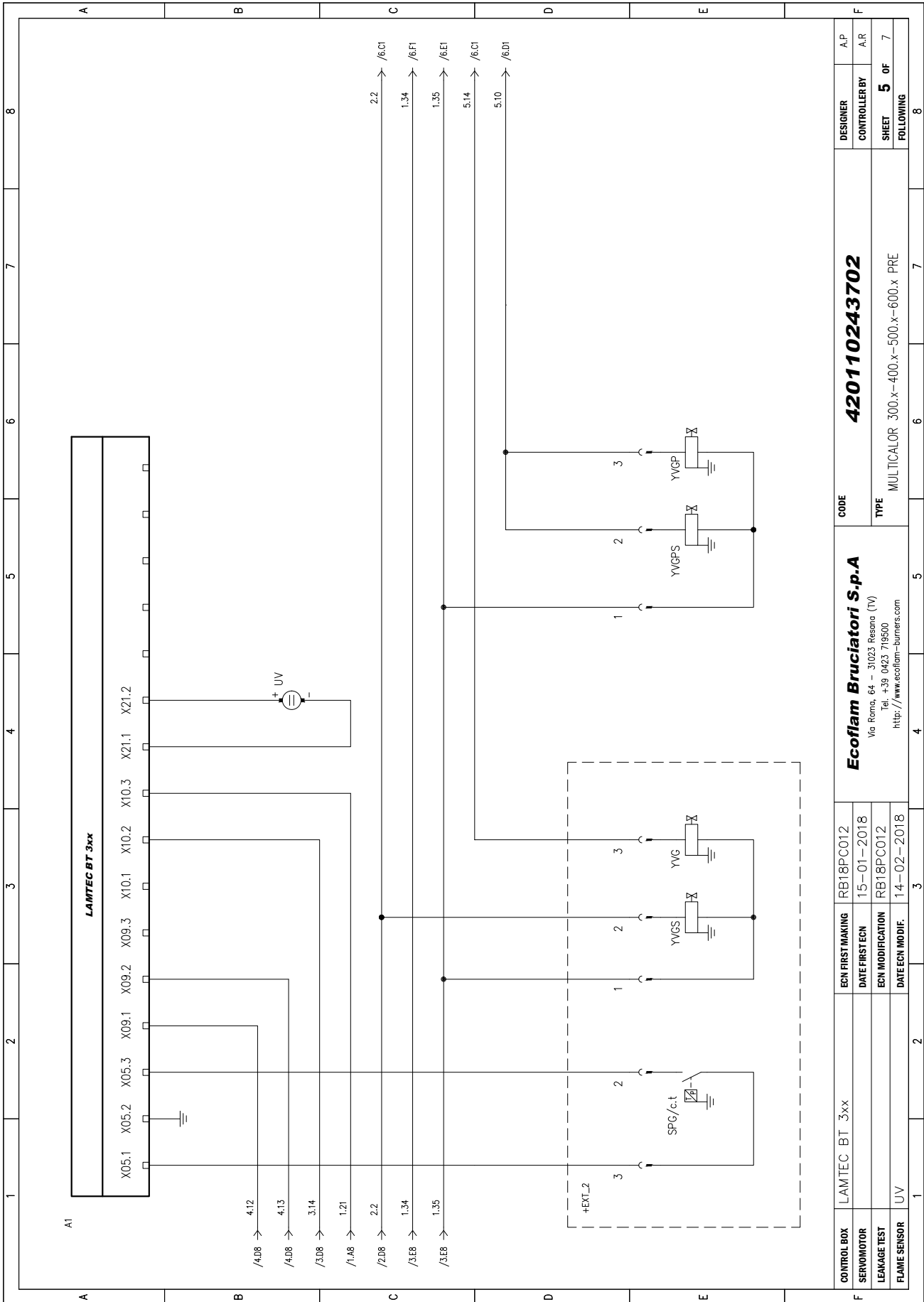

CONTROL BOX		ECON FIRST MAKING		CODE		DESIGNER	
LAMTEC BT 3xx	RB18PC012	RB18PC012	420110243702	A.P.			A.R.
SERVO MOTOR	15-01-2018	15-01-2018		CONTROLLER BY			
LEAKAGE TEST	RB18PC012	RB18PC012		SHEET	5 OF		7
FLAME SENSOR	UV	14-02-2018		FOLLOWING	8		
		Ecoflam Bruciatori S.p.A		TYPE		MULICALOR 300.x-400.x-500.x-600.x PRE	
		Via Roma, 64 - 31023 Resana (TV)		TYPE		MULICALOR 300.x-400.x-500.x-600.x PRE	
		Tel. +39 0423 719500		TYPE		MULICALOR 300.x-400.x-500.x-600.x PRE	
		http://www.ecoflam-burners.com		TYPE		MULICALOR 300.x-400.x-500.x-600.x PRE	

APPENDIX

Electrical diagrams

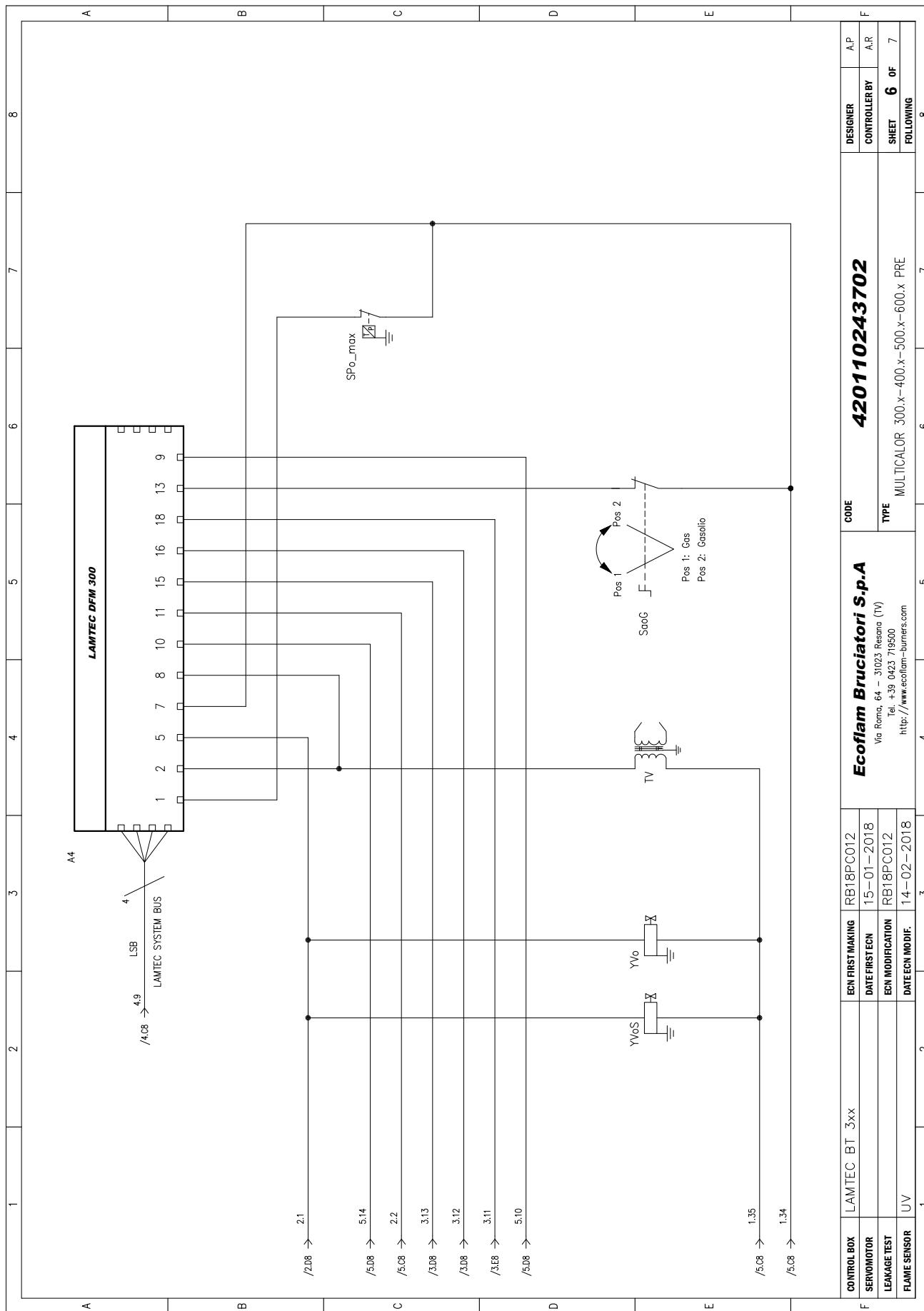

CONTROL BOX	LAMTEC BT 3xx	RB18PC012	CODE	420110243702		DESIGNER	A.P.
SERVO MOTOR		15-01-2018	Ecoflam Bruciatori S.p.A		CONTROLLER BY	A.R.	
LEAKAGE TEST		RB18PC012	Via Roma, 64 - 31023 Resana (TV)		SHEET	6 OF	7
FLAME SENSOR	UV	14-02-2018	Tel. +39 0423 719500		FOLLOWING		8
			http://www.ecoflam-burners.com				
			TYPE				
			MULTICALOR 300.x-400.x-500.x-600.x PRE				

APPENDIX

Electrical diagrams

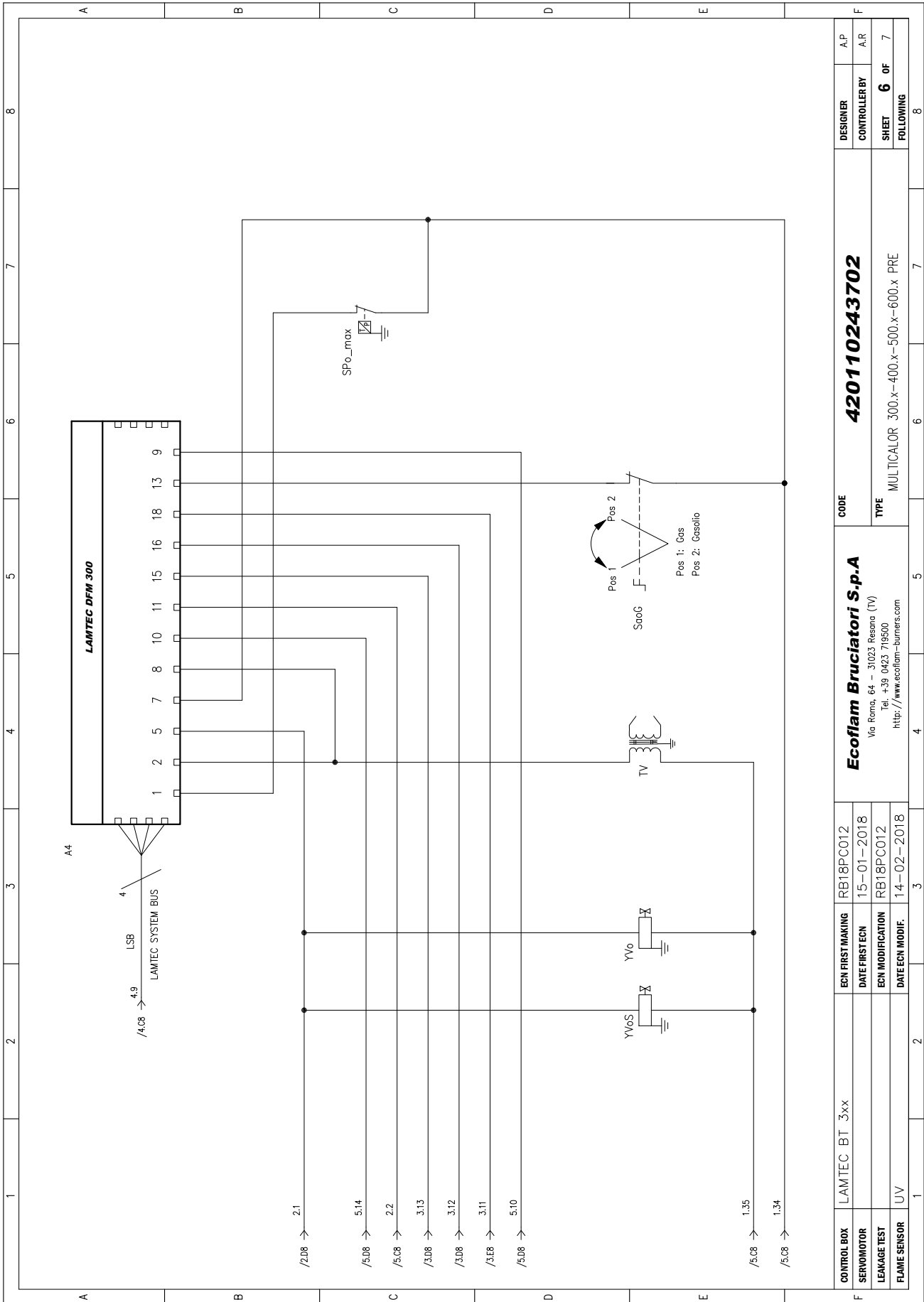

CONTROL BOX	LAMTEC BT 3xx	EEN FIRST MAKING	RB18PC012	CODE	420110243702		DESIGNER	A.P.
SERVO MOTOR		DATE FIRST EGN	15-01-2018	Ecoflam Bruciatori S.p.A			CONTROLLER BY	A.R.
LEAKAGE TEST		EEN MODIFICATION	RB18PC012	Via Roma, 64 - 31023 Resana (TV)			SHEET	6 OF 7
FLAME SENSOR	UV	DATE EGN MODIF.	14-02-2018	Tel. +39 0423 719500			FOLLOWING	8
				http://www.ecoflam-burners.com				
				TYPE		MULTICALOR 300.x-400.x-500.x-600.x PRE		

APPENDIX

Spare parts list

Multicalor 500.1 PRE
Multicalor 600.1 PRE

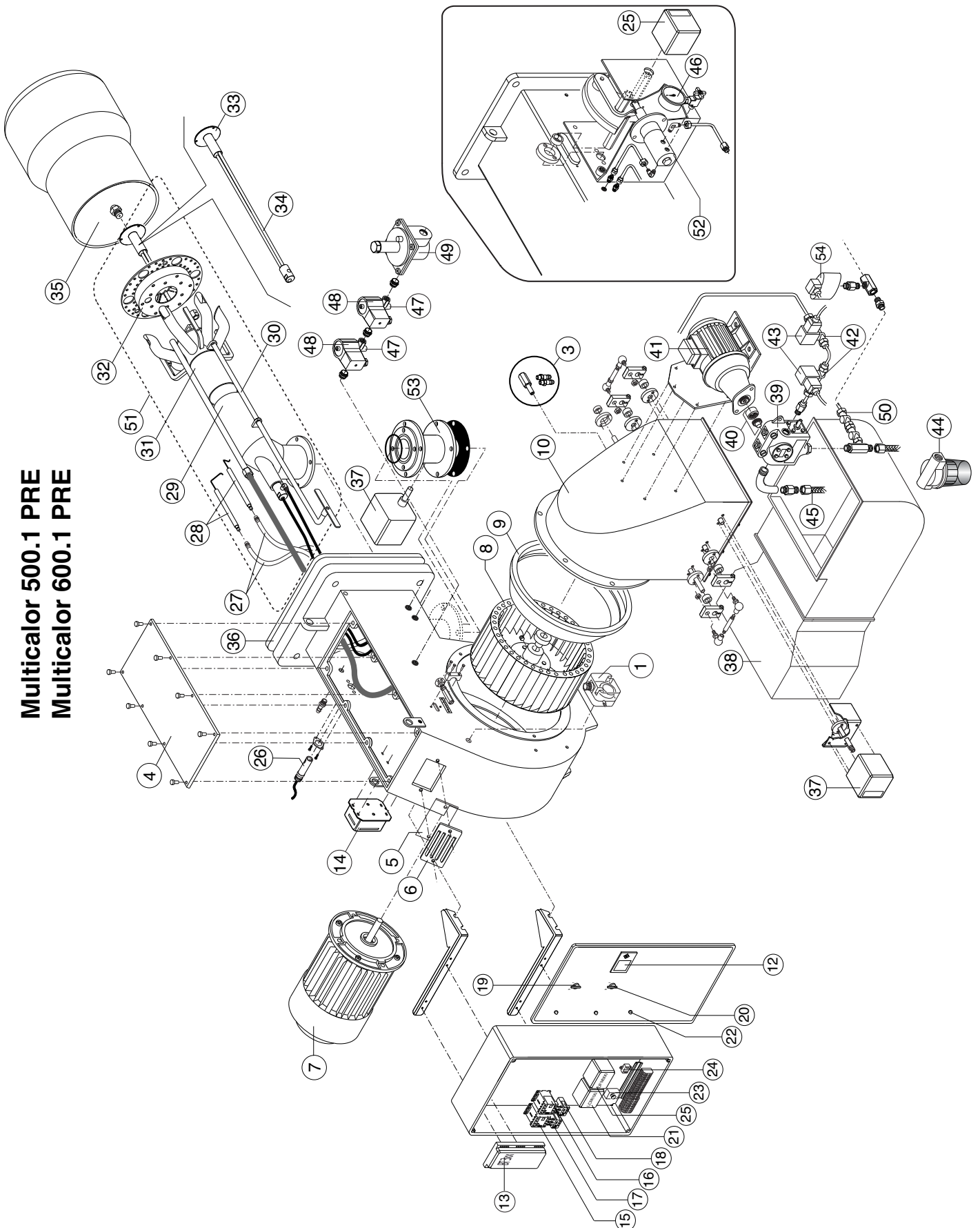

APPENDIX

Spare parts list

N°	DESCRIPTION		Multicalor 500.1 PRE	Multicalor 600.1 PRE
			code	code
1	AIR PRESSURE SWITCH	DUNGS LGW10 A2P	65323047	65323047
2	WIELAND PLUG		-	-
3	AIR INTAKE SET		65108676	65108676
4	COVER		65324490	65324490
5	GLASS		65320487	65320487
6	PEED WINDOM FRAME		65320488	65320488
7	MOTOR	11 k W	65326333	-
		15 k W	-	65326334
8	FAN	360 x 135	65321801	-
		380 x 135	-	65321802
9	AIR CONVEYOR		65324264	65324264
10	AIR INTAKE		840090094300	840090094300
11	AIR INTAKE PIPE		-	-
12	DISPLAY	LAMTEC UI300	65326932	65326932
13	CONTROL BOX	LAMTEC BT 340 667R1340-1	14058433	14058433
14	IGNITION TRANSFORMER	BRAHMA T8 13000/35 220/60	65323222	65323222
15	REMOTE CONTROL SWITCH	BF3800A230	65075273	65075273
16	REMOTE CONTROL SWITCH (PUMP)	BG0910 A230	65074309	65074309
17	MOTOR THERMAL RELAY	RF38 3200 V195 24-32 A	65327579	65327579
18	MOTOR THERMAL RELAY (PUMP)	LOVATO 11RF9 2-3,3 A	65074494	65074494
19	MAIN SWITCH	COMEPI art.ECX1040	65324098	65324098
20	GAS/LIGHT-OIL SELECTOR	COMEPI ART.E	65324278	65324278
21	LOAD CONTROL UNIT	LCM100	65311790	65311790
22	LAMP	LYVIA 10X28 BA9S	65324100	65324100
		RED LED	65325033	65325033
		GREEN LED	65325034	65325034
		YELLOW LED	65325044	65325044
23	FUSE SUPPORT	HK 520 04-1 10A	65324279	65324279
24	ANTIJAMMING FILTER		65323170	65323170
25	DUAL-FUEL MODULE	DMF300	65311791	65311791
26	UV CELL	SIEMENS QRA 2	65320075	65320075
27	IGNITION CABLE	TC	65320947	65320947
		TL	65320947	65320947
28	IGNITION ELECTRODES SET		65325222	65325222
29	PIPE	TC	65321675	65321675
		TL	65324491	65324491
30	ROD	TC	65324492	65324492
		TL	65324434	65324434
31	FIRING HEAD		65321676	65321676
32	FRONT DISC		65324157	65324157
33	NOZZLE HOLDER		-	-
34	LIGHT OIL FIRING HEAD	TC	65324494	65324494
		TL	65324769	65324769
35	BLAST TUBE	TC	65324815	65324815
		TL	65324816	65324816
36	GASKET ISOMART		65321128	65321128
37	DAMPER MOTOR	STE4,5 Q3.51/6 3NM	65311650	65311650
		STE 4,5 B0.37/6-R 0.8NM	65300527	65300527
38	SILENCER		3141914	3141914
39	OIL PUMP	SUNTEC TA4C40106	65322994	65322994
40	COUPLING		65325386	65325386
41	PUMP MOTOR	1,1 kW	65325356	65325356
42	OIL VALVE	LUCIFER 1/2 E321H25-4270	65323633	65323633
43	COIL	LUCIFER 1/2 E321H25-4270	65323810	65323810
44	OIL FILTER	MOD.70501/03 GR.	65324103	65324103
45	HOSES	TN 18X1500	65323182	65323182
46	MANOMETER	CEWAL R1/4 D50-40BAR	65324105	65324105
47	PILOT GAS VALVE	BRAHMA EG12SR GFD	65323595	65323595
48	COIL	BRAHMA	65323707	65323707
49	GAS GOVERNOR	1/2 FG1B 15	65325207	65325207
50	CHECK VALVE	ART. FZVR10 3/8	65325066	65325066
51	INNER ASSEMBLY	TC		
		TL		
52	ADJUSTMENT OF OIL PRESSURE	PR80 HRC42-46 d11x20	65324304	65324304
53	THROTTLE GROUP		840090179100	840090179100
54	OIL PRESSURE SWITCH	DSB158 F931, 0-25BAR	65312206	65312206

TC = SHORT HEAD TL = LONG HEAD

Ecoflam

Ecoflam Bruciatori S.p.A.

Via Roma, 64 - 31023 Resana (TV) - Italy

Tel. +39 0423 719500

Fax +39 0423 719580

<http://www.ecoflam-burners.com>

e-mail: export@ecoflam-burners.com

Società soggetta alla direzione e al coordinamento di Ariston Thermo S.p.A.

Via A. Merloni, 45 - 60044 Fabriano (AN) - CF 01026940427

Ecoflam Bruciatori S.p.A. reserves the right to make any adjustments, without prior notice, which is considered necessary or useful to its products, without affecting their main features

Ecoflam Bruciatori S.p.A. si riserva il diritto di apportare ai prodotti le modifiche che riterrà necessarie o utili, senza pregiudicarne le caratteristiche principali.

La maison Ecoflam Bruciatori S.p.A. se réserve le droit d'apporter les modifications qu'elle jugera nécessaires ou utiles à ses produits sans pour autant nuire à leurs caractéristiques principales

Ecoflam Bruciatori S.p.A. se reserva el derecho a introducir en sus productos todas las modificaciones que considere necesarias o utiles, sin perjudicar sus características

"Ecoflam Bruciatori S.p.A." оставляет за собой право вносить в конструкцию оборудования любые необходимые изменения без особого предупреждения